

This file is available for free download at <http://www.iluvmyrx7.com>

This file was not scanned to deprive Mazda of any money – it was scanned due to the rareness of the original manuals and the overwhelming need of the RX-7 owner to have this information so that they can accurately troubleshoot problems. Perhaps if Mazda's dealerships could support the Rotary Engine it wouldn't be so necessary for the owners to do so.



Many thanks to Anh Diep for scanning this file.

FRONT AND REAR AXLES

INDEX	M - 2
OUTLINE	M - 3
SPECIFICATIONS	M - 3
TROUBLESHOOTING GUIDE	M - 3
FRONT AXLE	M - 4
PREPARATION	M - 4
WHEEL HUB / STEERING KNUCKLE	M - 4
REAR AXLE	M - 9
PREPARATION	M - 9
WHEEL HUB	M - 9
DRIVE SHAFT	M -14
PREPARATION	M -14
DRIVE SHAFT (TRIPOD JOINT)	M -14
DIFFERENTIAL	M -22
PREPARATION	M -22
DIFFERENTIAL OIL	M -23
OIL SEAL	M -24
DIFFERENTIAL (TORQUE SENSING LSD) ...	M -27

INDEX

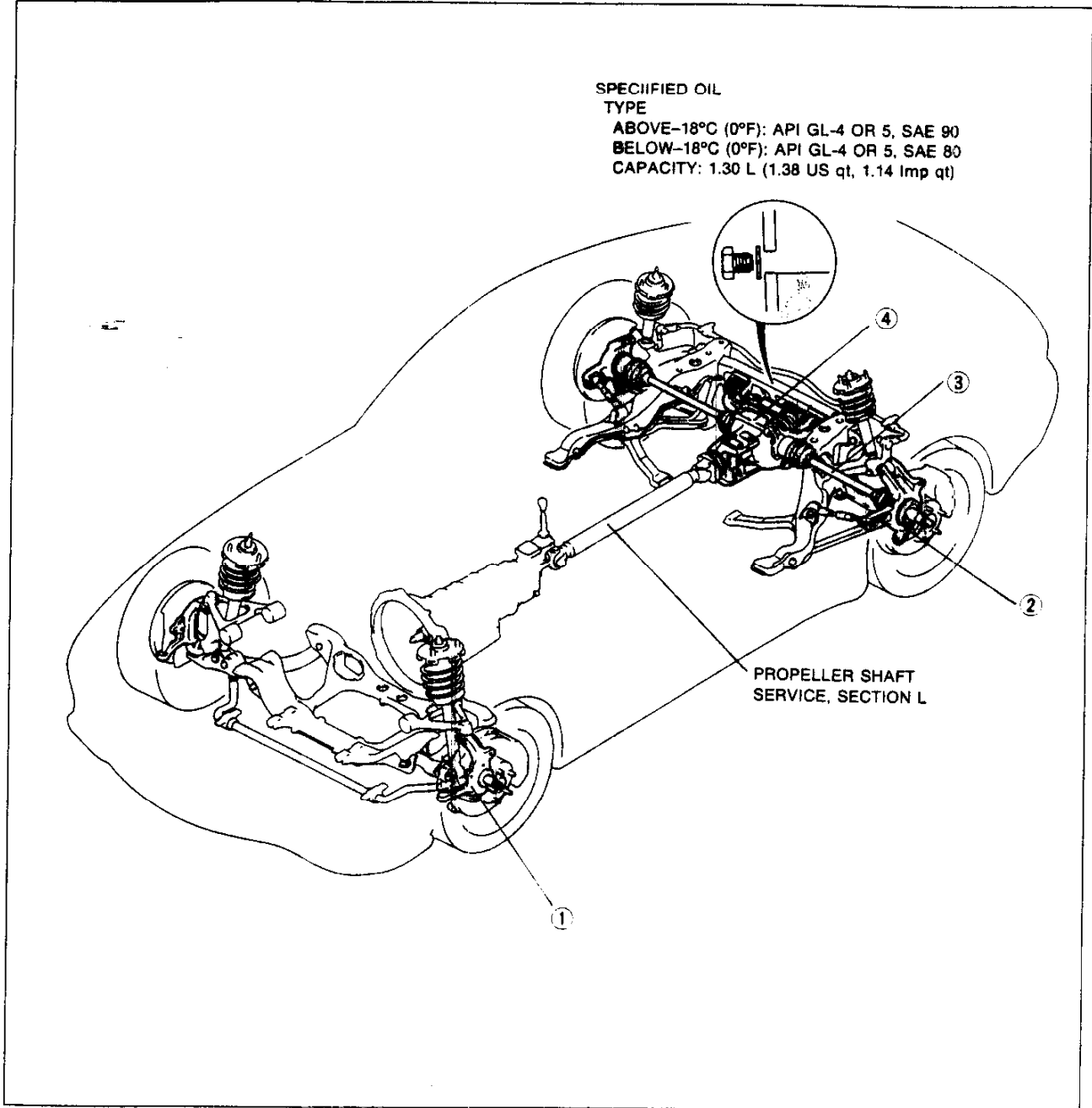

37U0MX-002

1. Front axle		
Preinspection	page M- 4	
Removal / Inspection / Installation	page M- 5	
Disassembly / Inspection / Assembly	page M- 7	
2. Rear axle		
Preinspection	page M- 9	
Removal / Inspection / Installation	page M-10	
Disassembly / Inspection / Assembly	page M-12	
3. Drive shaft		
Preinspection	page M-14	
Removal / Installation	page M-15	
Overhaul	page M-18	
4. Differential		
Differential oil	page M-23	
Oil seal	page M-24	
Removal / Installation	page M-27	
Disassembly / Inspection	page M-30	
Assembly	page M-34	

OUTLINE

SPECIFICATION

Item	Engine / Transmission		13B	
			MT	AT
Front axle				
Bearing type	Unitized angular ball bearing			
Rear axle				
Bearing type	Unitized angular ball bearing			
Drive shaft				
Type	Constant velocity joint			
Length (between centers of joints)	mm {in}	484.2 {19.06}		
Diameter	mm {in}	29.0 {1.14}		
Differential				
Type	Torque sensing LSD			
Reduction gear	Hypoid gear			
Differential gear	Worm gear			
Reduction ratio			4.100	3.909
Number of teeth	Ring gear	41		43
	Drive pinion gear	10		11
Ring gear size	mm {in}	204.2 {8.038}		
Oil	Grade	mm {in}	API service GL-4 or 5	
	Viscosity	Above- 18°C (0°F): SAE 90 Below- 18°C (0°F): SAE 80		
	Capacity	L {US qt, Imp qt}	1.30 {1.38, 1.14}	

37U0MX-003

TROUBLESHOOTING GUIDE

Problem	Possible Cause	Action	Page
Front axle			
Steering wheel vibration	Worn or damaged wheel bearing	Replace	M- 5
Pulls or one-sided braking	Worn or damaged wheel bearing	Replace	M- 5
Rear axle			
Abnormal noise	Worn or damaged wheel bearing	Replace	M-12
	Bent drive shaft	Replace	M-15
	Worn drive shaft spline	Replace	M-15
Differential			
Abnormal noise	Insufficient differential oil	Add oil	M-23
	Incorrect differential oil	Replace	M-23
	Worn or damaged side bearing	Replace	M-30
	Worn or damaged ring gear	Replace	M-30
	Worn or damaged drive pinion bearing	Replace	M-30
	Worn or damaged gear in LSD assembly	Replace gear case	M-30
	Worn side gear spline	Replace	M-30
	Improperly adjusted drive pinion gear preload	Adjust	M-38
	Improperly adjusted ring gear backlash	Adjust	M-39
Poor contact of ring gear teeth	Adjust	M-41	
Heat buildup	Insufficient differential oil	Add oil	M-23
	Insufficient drive pinion gear backlash	Adjust	M-39
	Excessive bearing preload	Adjust	M-38
Oil leakage	Excessive differential oil	Remove oil	M-23
	Worn or damaged oil seal	Replace	M-24
	Loose differential carrier	Tighten or repair	M-30
No differential operation	Misassembled or damaged	Repair or replace	M-30

37U0MX-004

M

FRONT AXLE

FRONT AXLE

PREPARATION SST

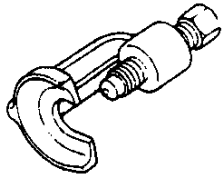
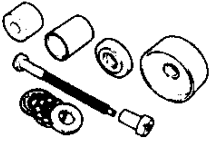
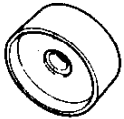
<p>49 0118 850C Puller, ball joint</p> 	<p>For removal of ball joint</p>	<p>49 H028 2A0 Replacer set, rubber bushing</p> 	<p>For installation of ABS sensor rotor</p>
<p>49 H028 204 Attachment (Part of 49 H028 2A0)</p> 	<p>For installation of ABS sensor rotor</p>	<p>37U0MX-005</p>	

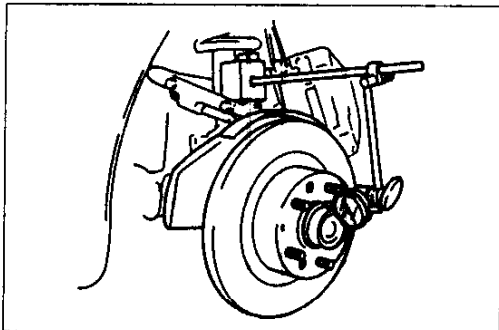

37U0MX-006

WHEEL HUB / STEERING KNUCKLE

Preinspection

Wheel bearing play

1. Position a dial indicator against the wheel hub.
2. Push and pull the wheel hub by hand in the axial direction and measure the wheel bearing play.
3. If the bearing play exceeds specification, check and adjust the wheel hub nut torque or replace the wheel hub assembly, if necessary.

Wheel bearing play: 0.05 mm {0.002 in} max.

Removal / Inspection / Installation

1. Jack up the front of the vehicle and support it on safety stands.
2. Remove the wheel.
3. Remove in the order shown in the figure, referring to **Removal Note**.
4. Inspect all parts and repair or replace as necessary.
5. Install in the reverse order of removal, referring to **Installation Note**.
6. Install the wheel. (Tightening torque: 89–117 N·m {9.0–12.0 kgf·m, 65–86 in·lb})
7. After installation, check the front wheel alignment. (Refer to Section R.)

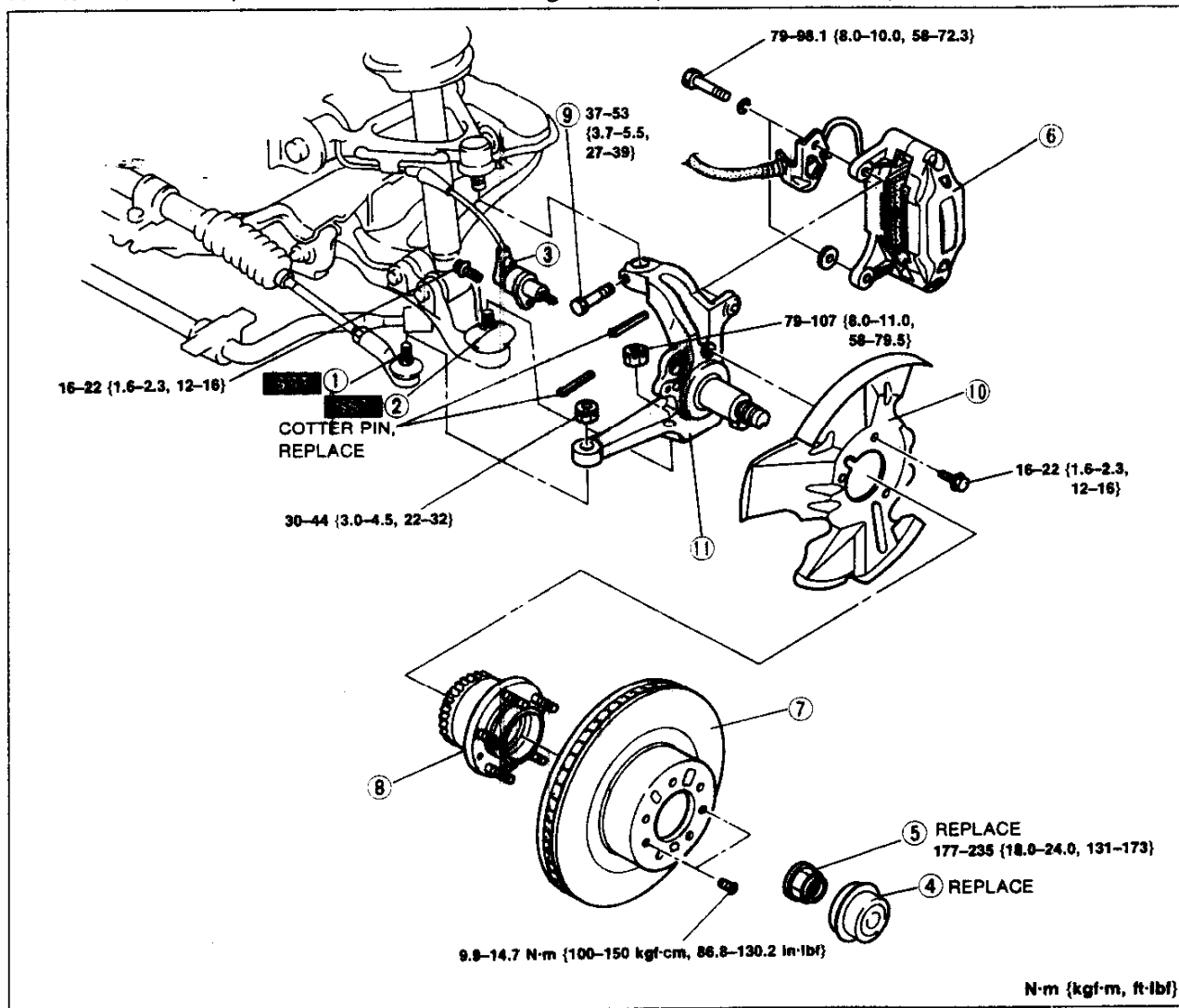

37U0MX-007

- | | |
|---|---|
| <ol style="list-style-type: none"> 1. Tie rod end ball joint
Removal Note page M-6
Service Section N 2. Lower arm ball joint
Removal Note page M-6
Service Section R 3. ABS wheel-speed sensor
Service Section P 4. Hub cap 5. Wheel hub nut
Installation Note page M-6 6. Brake caliper assembly
Removal Note page M-6
Service Section P | <ol style="list-style-type: none"> 7. Disc plate
Service Section P 8. Wheel hub assembly
Inspect for cracks and damage
Inspect bearing for rough rotation
Disassembly / Inspection /
Installation page M-7 9. Bolt (upper arm) 10. Dust cover
Inspect for cracks and damage 11. Steering knuckle
Inspect for cracks and damage |
|---|---|

FRONT AXLE

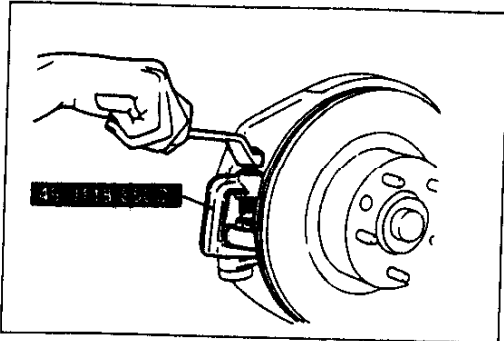

37U0MX-009

Removal note Tie rod end ball joint

1. Loosen the tie rod end nut until it is flush with the end of the stud.
2. With the nut protecting the tie rod end stud, separate the tie rod end from the steering knuckle by using the **SST**.

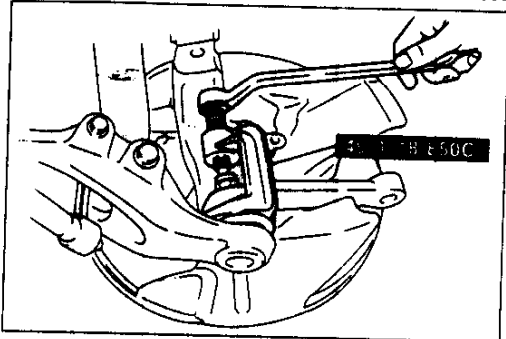

37U0MX-010

Lower arm ball joint

1. Loosen the nut until it is flush with the end of the stud.
2. With the nut protecting the ball joint stud, separate the ball joint from the knuckle by using the **SST**.

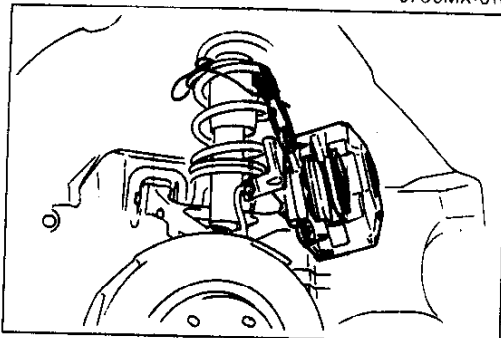

37U0MX-011

Brake caliper assembly

Hang the brake caliper assembly out of the way as shown in the figure.

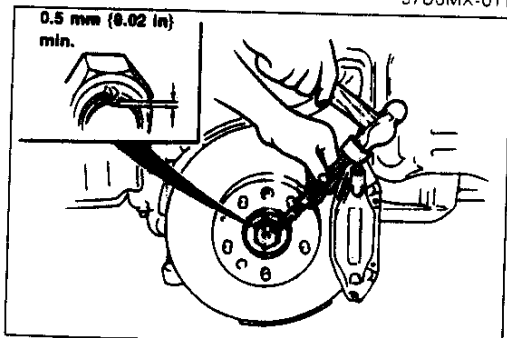

37U0MX-012

Installation note Wheel hub nut

1. Install a new hub nut and stake it as shown.

Tightening torque:

177–235 N·m {18.0–24.0 kgf·m, 131–173 ft·lbf}

2. Measure the wheel bearing play. (Refer to page M-4.)

Disassembly / Inspection / Assembly

1. Disassemble in the order shown in the figure, referring to **Disassembly Note**.
2. Inspect all parts and repair or replace as necessary.
3. Assemble in the reverse order of disassembly, referring to **Assembly Note**.

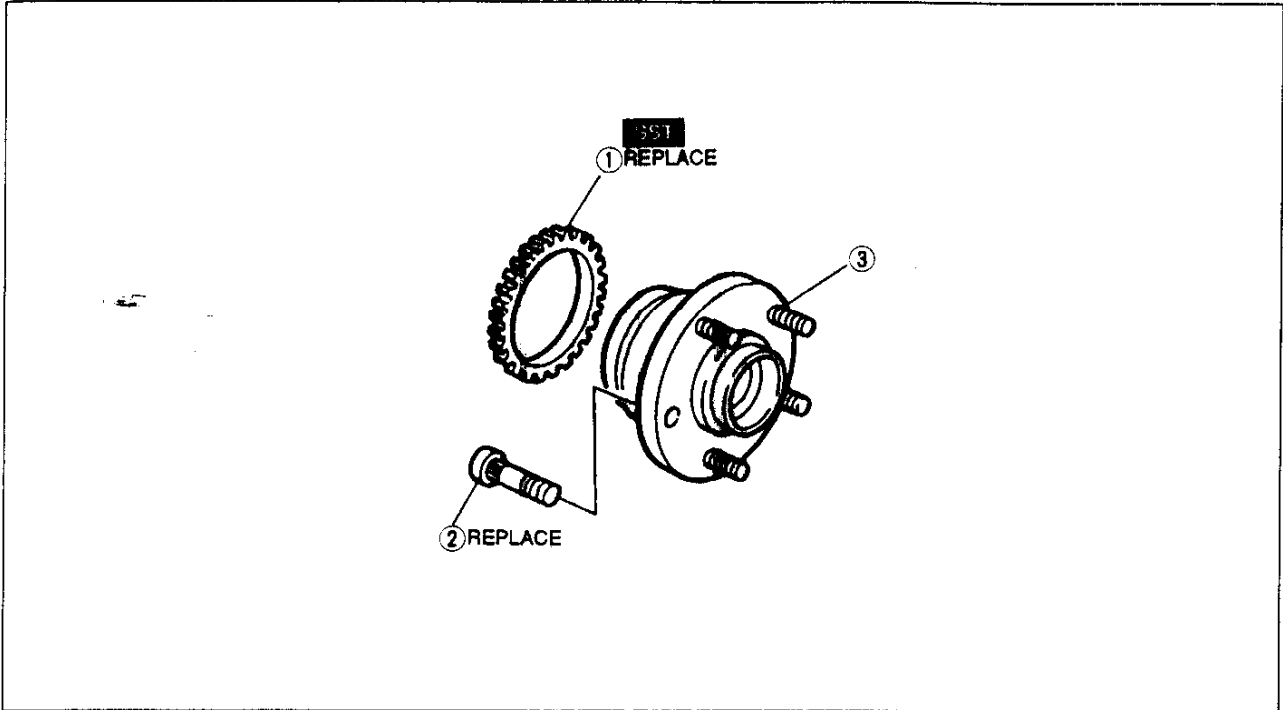

37U0MX-013

- | | |
|--|---|
| <p>1. ABS sensor rotor
 Disassembly Note below
 Assembly Note page M-8</p> | <p>3. Wheel hub
 Inspect bearing for rough rotation
 (Not repairable, replace hub assembly)</p> |
| <p>2. Hub bolt
 Disassembly Note below
 Assembly Note page M-8</p> | |

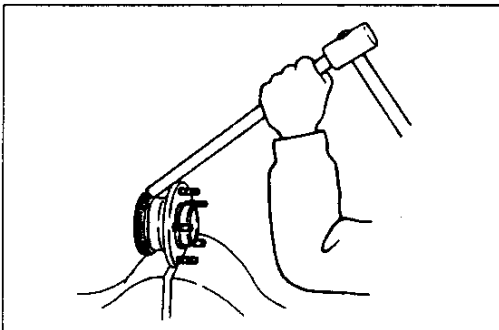

37U0MX-014

**Disassembly note
ABS sensor rotor**

Caution

- Do not remove the sensor rotor if not necessary.
- Do not reuse the sensor rotor if removed.

Remove the sensor rotor by using a brass bar and a hammer.

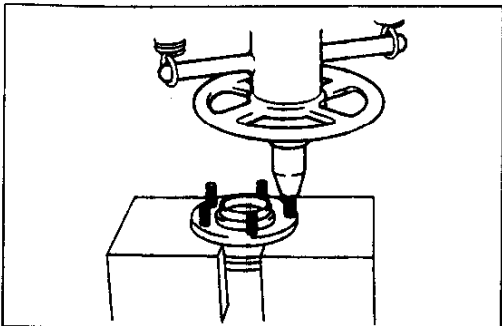

28U0MX-012

Hub bolt

Caution

- Do not remove the hub bolts if not necessary.
- Do not reuse the hub bolts if removed.

Remove the hub bolts by using a press.

M

FRONT AXLE

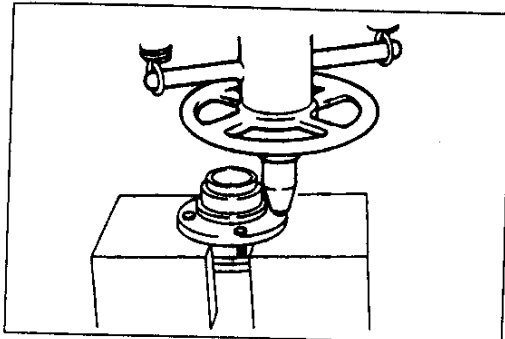

29U0MX-013

Assembly note Hub bolt

Press in new hub bolts.

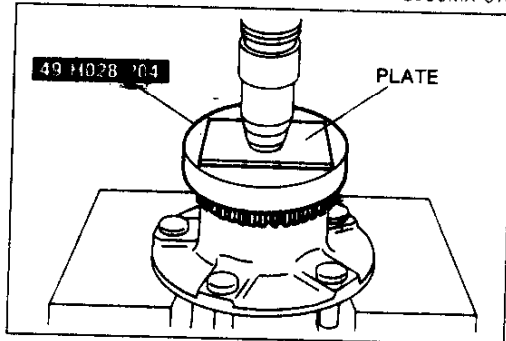



37U0MX-015

ABS sensor rotor

Press on the new sensor rotor by using the **SST**.

REAR AXLE

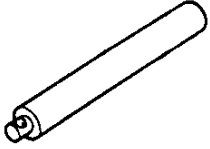
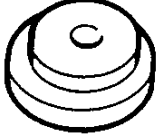
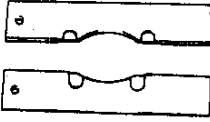
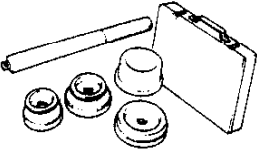
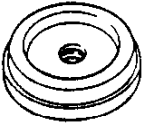
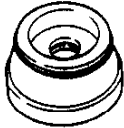
PREPARATION
SST

<p>49 G033 102 Handle</p> 	<p>For removal of axle flange</p>	<p>49 G033 105 Attachment</p> 	<p>For removal of axle flange</p>
<p>49 F026 103 Plate, removing</p> 	<p>For removal of axle flange</p>	<p>49 F027 0A1 Installer set, bearing</p> 	<p>For removal of wheel bearing and installation of axle flange</p>
<p>49 F027 004 Attachment (Part of 49 F027 0A1)</p> 	<p>For installation of wheel bearing</p>	<p>49 F027 005 Attachment (part of 49 F027 0A1)</p> 	<p>For removal of wheel bearing and installation of axle flange</p>
<p>49 H034 201 Block, support</p> 	<p>For installation of wheel bearing</p>	<p>37U0MX-016</p>	

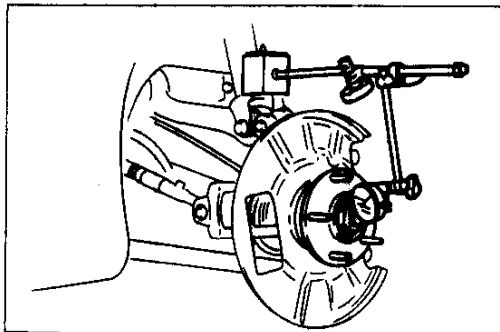

37U0MX-017

WHEEL HUB

Preinspection

Wheel bearing play

1. Position a dial indicator against the wheel hub.
2. Push and pull the wheel hub by hand in the axial direction and measure the wheel bearing play.
3. If the bearing play exceeds specification, check and adjust the wheel hub nut torque or replace the wheel bearing, if necessary.

Wheel bearing play: 0.05 mm {0.002 in} max.

M

REAR AXLE

Removal / Inspection / Installation

1. Jack up the rear of the vehicle and support it on safety stands.
2. Remove the wheel.
3. Remove in the order shown in the figure, referring to **Removal Note**.
4. Inspect all parts and repair or replace as necessary.
5. Install in the reverse order of removal, referring to **Installation Note**.
6. Install the wheel. (Tightening torque: 89–117 N·m {9.0–12.0 kgf·m, 65–86 ft·lbf})
7. After installation, check the rear wheel alignment. (Refer to Section R.)

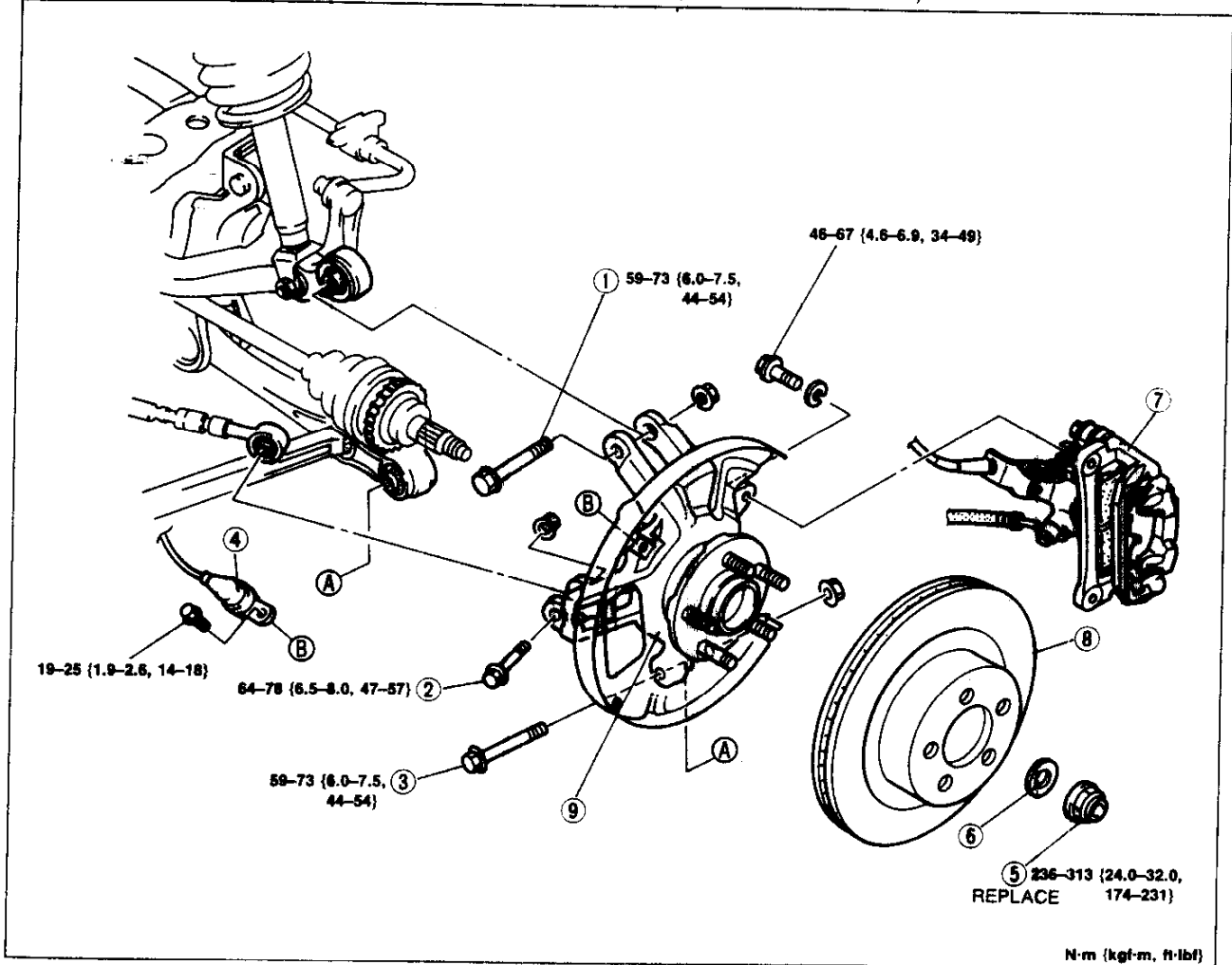

N·m (kgf·m, ft·lbf)

37U0MX-018

- | | |
|-----------------------------------|------------------------------|
| 1. Bolt (upper arm) | 7. Brake caliper assembly |
| 2. Bolt (toe control link) | Removal Note page M-11 |
| 3. Bolt (l-arm) | Service Section P |
| 4. ABS wheel-speed sensor | 8. Disc plate |
| Service Section P | Service Section P |
| 5. Wheel hub nut | 9. Rear hub support assembly |
| Installation Note page M-11 | Removal Note page M-11 |
| 6. Washer | Disassembly / Inspection / |
| | Assembly page M-12 |

2.
3. F

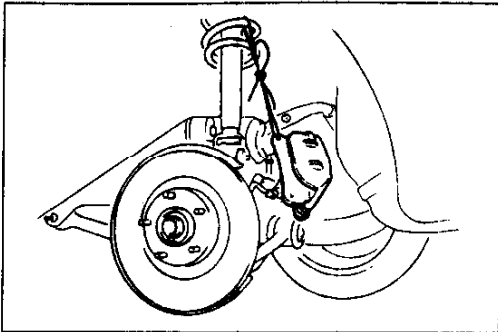

37U0MX-020

Removal note
Brake caliper assembly

Hang the brake caliper assembly as shown in the figure.

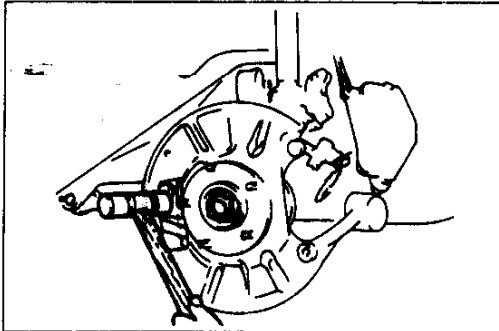

37U0MX-021

Rear hub support assembly

Note

- If the drive shaft is stuck to the wheel hub, install a used nut until it is flush with the end of the shaft. Tap the nut with a brass hammer to drive out the drive shaft.

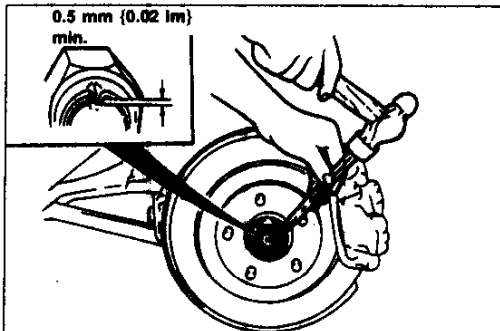

37U0MX-022

Installation note
Wheel hub nut

1. Install a new hub nut and stake it as shown.

Tightening torque:

236–313 N·m {24.0–32.0 kgf·m, 174–231 ft·lbf}

2. Check the wheel bearing play. (Refer to page M-9.)

M

REAR AXLE

Disassembly / Inspection / Assembly

1. Disassemble in the order shown in the figure, referring to **Disassembly Note**.
2. Inspect all parts and repair or replace as necessary.
3. Assemble in the reverse order of disassembly, referring to **Assembly Note**.

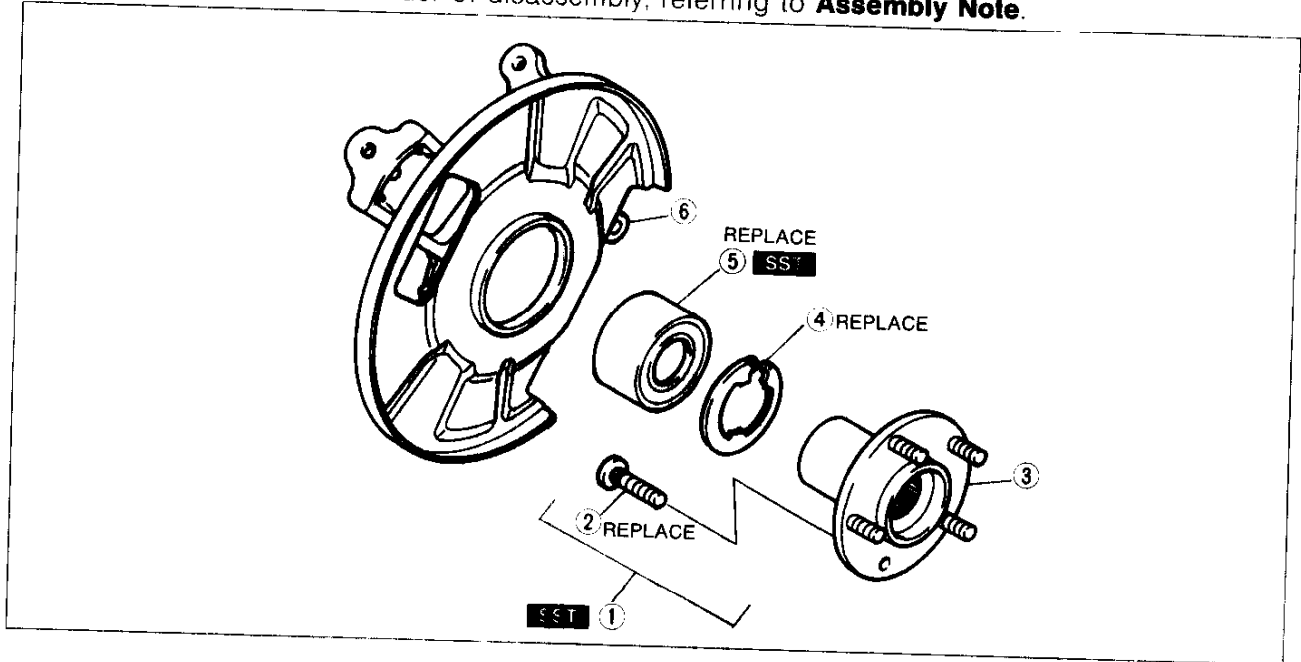

37U0MX-023

- | | |
|--|--|
| <ol style="list-style-type: none"> 1. Axle flange assembly
Disassembly Note below
Assembly Note page M-13 2. Hub bolt
Disassembly Note page M-13
Assembly Note page M-13 | <ol style="list-style-type: none"> 3. Axle flange
Inspect for cracks and damage 4. Retaining ring 5. Wheel bearing
Disassembly Note page M-13
Assembly Note page M-13 6. Rear hub support assembly
Inspect for cracks and damage |
|--|--|

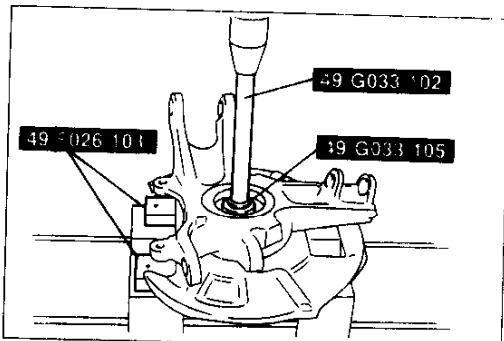

37U0MX-024

Disassembly note Axle flange assembly

1. Remove the axle flange assembly by using the **SST**.

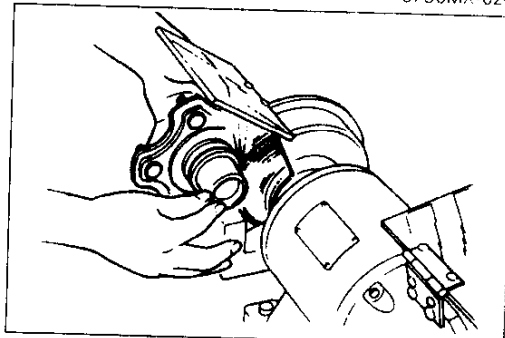

37U0MX-025

Caution

- **Do not damage the axle flange.**
2. Grind a section of the bearing race until **approx. 0.5 mm {0.02 in}** thickness remains.
 3. Cut the race by using a chisel and remove it.

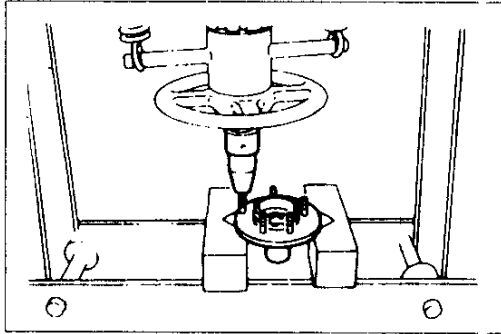

29U0MX-C-26

Hub bolt

Caution

- Do not remove the hub bolts if not necessary.
- Do not reuse the hub bolts if removed.

Remove the hub bolts by using a press.

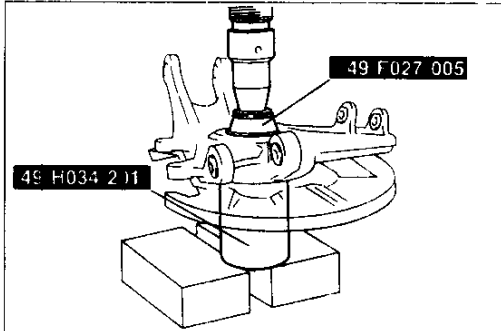

29U0MX-C-27

Wheel bearing

Remove the wheel bearing by using the **SST**.

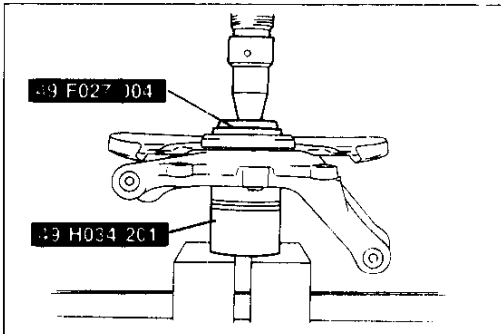

29U0MX-C-28

Assembly note
Wheel bearing

Install the new wheel bearing by using the **SST**.

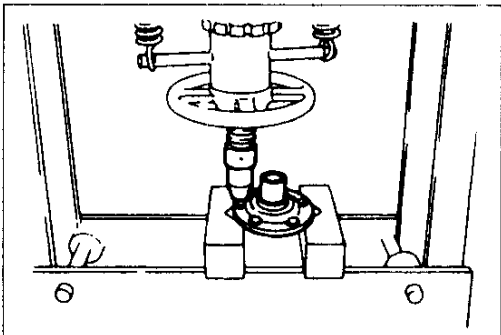

29U0MX-C-29

Hub bolt

Press in new hub bolts.

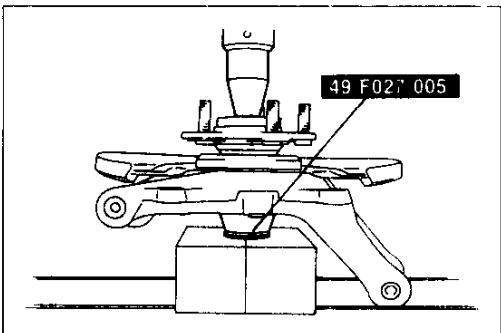

29U0MX-C-30

Axle flange assembly

Install the axle flange assembly by using the **SST**.

DRIVE SHAFT

PREPARATION

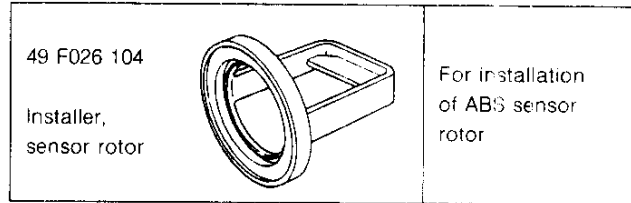

37U0MX-026

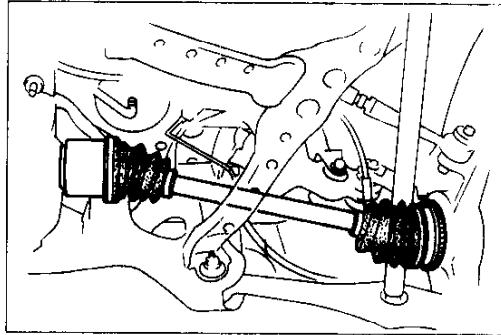

37U0MX-027

DRIVE SHAFT (TRIPOD JOINT)

Preinspection

Drive shaft

1. Check the dust boot on the drive shaft for cracks, damage, grease leakage, and a loose boot band.
2. Check the drive shaft for bending, cracks, and wear of the joints and splines.
3. Repair or replace the drive shaft as necessary.

Removal / Installation

1. Jack up the rear of the vehicle and support it on safety stands.
2. Remove the wheel.
3. Remove in the order shown in the figure, referring to **Removal Note**.
4. Install in the reverse order of removal, referring to **Installation Note**.
5. Install the wheel. (Tightening torque: 89–117 N·m {9.0–12.0 kgf·m, 65–86 ft·lbf})
6. Check the rear wheel alignment. (Refer to Section R.)

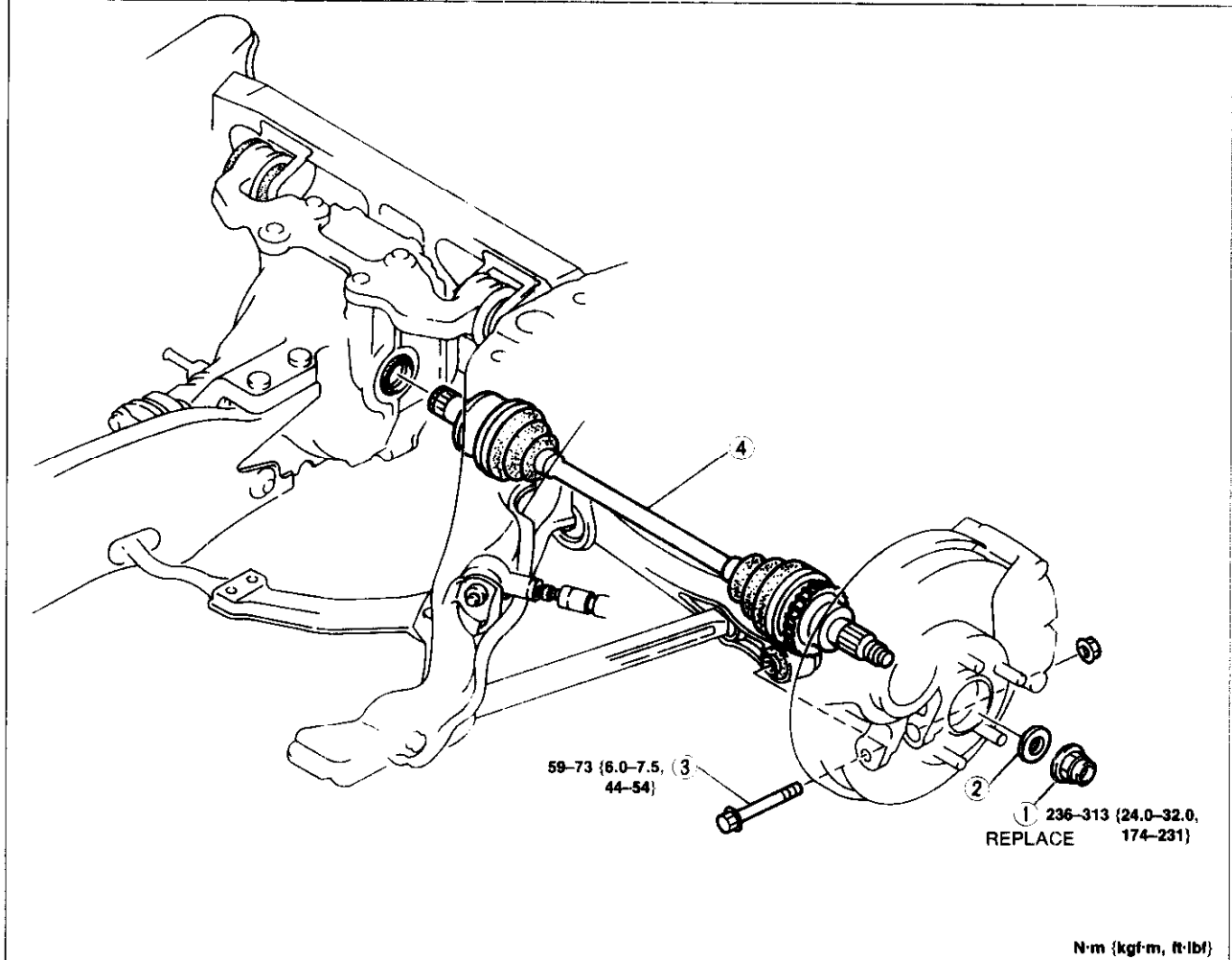

37U0MX-028

1. Wheel hub nut
Removal Note page M-16
Installation Note page M-17
2. Washer
3. Bolt (I-arm)

4. Drive shaft
Removal Note page M-16
Installation Note page M-16
Overhaul page M-18

N**DI****PR**

48

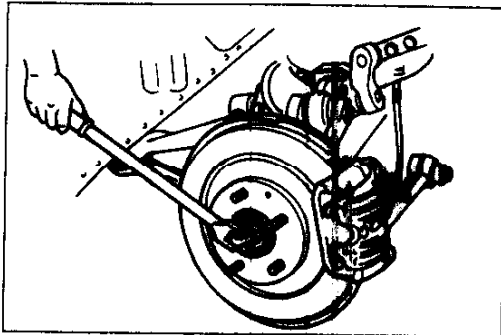
In
se**M****DRIVE SHAFT**

370MX-029

Removal note
Wheel hub nut**Caution**

- Do not damage the drive shaft.

1. Raise the staked portion of the hub nut by using a chisel.
2. Lock the hub by applying the parking brakes.
3. Remove the hub nut.

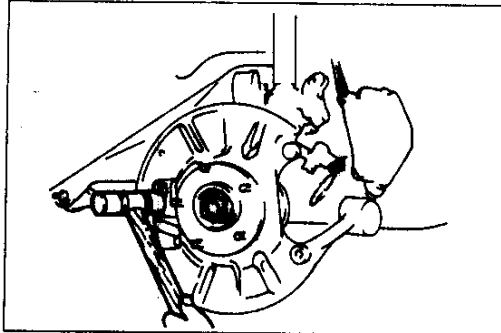

37U0MX-030

Drive shaft**Note**

- If the drive shaft is stuck in the rear hub support, install a used nut until it is flush with the end of the shaft. Tap the nut with a brass hammer to drive the drive shaft.

1. Pull the rear hub support from the drive shaft.

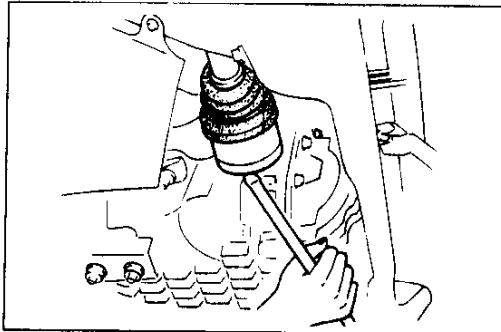

37U0MX-031

Caution

- Do not damage the oil seal.

2. Remove the drive shaft from the differential by using a pry bar.

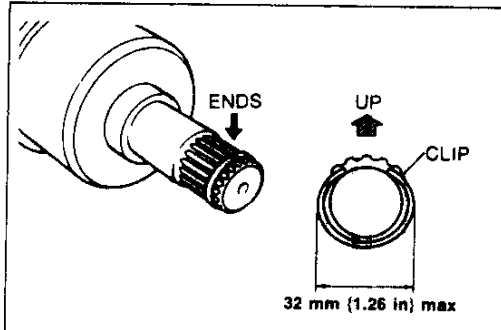

37U0MX-032

Installation note**Drive shaft****Caution**

- Do not excessively spread the clip when installing it.
- Measure the outside diameter of the clip after installing it on the shaft. Replace the clip if it exceeds the specification.

1. Install a new clip on the drive shaft.

Caution

- Do not damage the oil seal.

2. With the ends of the clip facing upward, push the drive shaft into the differential.

Note

- After installation, pull outward on the tripod joint outer ring and verify that the drive shaft is held in place by the clip.

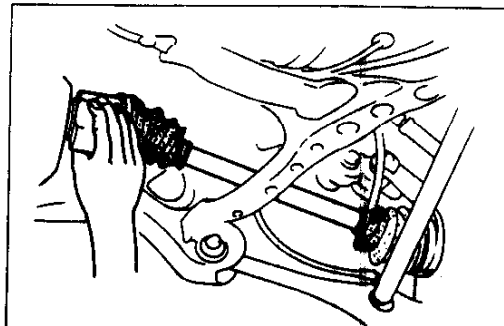

37UMX-033

M-**M-16**

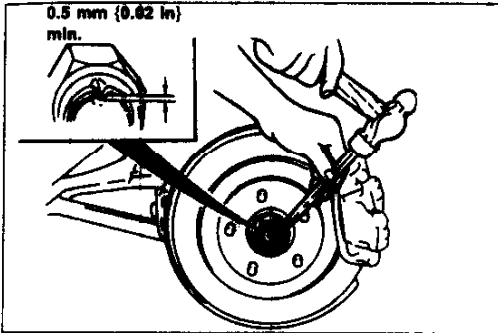

37UOMX-034

Wheel hub nut

1. Install a new hub nut and stake it as shown.

Tightening torque:

236–313 N·m {24.0–32.0 kgf·m, 174–231 ft·lb}

2. Check the wheel bearing play. (Refer to page M-9.)

M

DRIVE SHAFT

Overhaul

Caution

- Secure the joint in a vise with protective material (such as aluminum plates) on the vise jaws.
 - Be careful that dust or other foreign material does not enter the joint while the work is being performed.
 - Do not disassemble the wheel side ball joint.
 - Do not wash the joint unless it is being disassembled.
1. Disassemble in the order shown in the figure, referring to **Disassembly Note**.
 2. Inspect all parts and repair or replace as necessary.
 3. Assemble in the reverse order of disassembly, referring to **Assembly Note**.

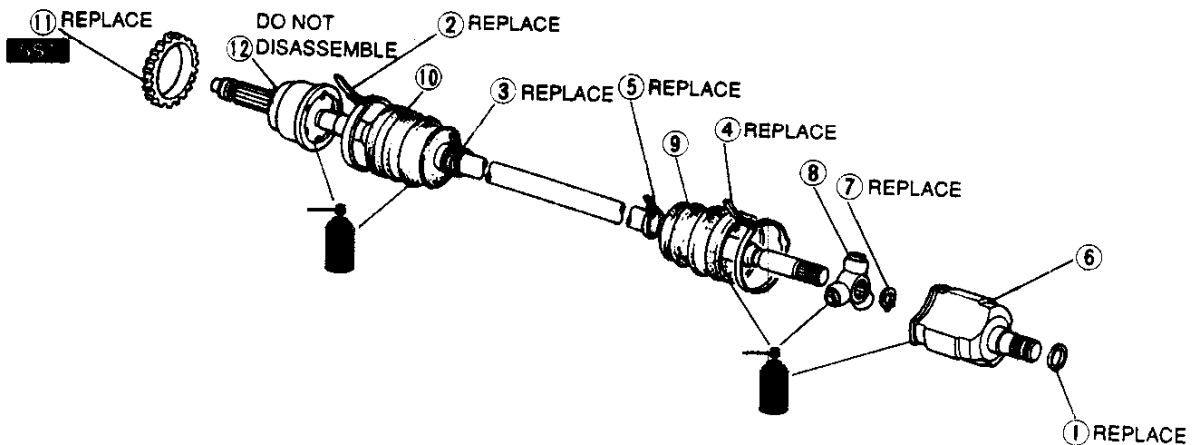

37UOMX-035

- 1. Clip
Disassembly Note below
Assembly Note page M-21
- 2. Boot band
Disassembly Note below
Assembly Note page M-21
- 3. Boot band
Disassembly Note below
Assembly Note page M-21
- 4. Boot band
Disassembly Note below
Assembly Note page M-21
- 5. Boot band
Disassembly Note below
Assembly Note page M-21
- 6. Outer ring
Disassembly Note below
Inspect inside bore for wear,
corrosion, and scoring
Assembly Note page M-21
- 7. Snap ring
Disassembly Note below
Assembly Note page M-21
- 8. Tripod joint
Disassembly Note below
Inspect for wear and damage
Assembly Note page M-21
- 9. Boot
Disassembly Note page M-20
Inspect for damage
Assembly Note page M-20
- 10. Boot
Disassembly Note page M-20
Inspect for damage
Assembly Note page M-20
- 11. ABS sensor rotor
Disassembly Note page M-20
Assembly Note page M-20
- 12. Shaft and ball joint assembly
Inspect splines for damage and wear
Inspect wheel-side joint for excessive
play and rough rotation.

37U0MX-036

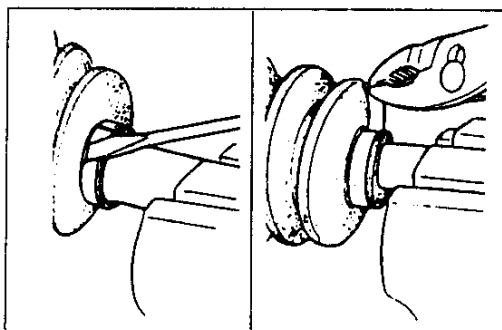

37U0MX-037

**Disassembly note
Boot band**

Caution

- Do not remove the wheel side boot band if not necessary.

1. Pry up the locking tabs of the boot band by using a screwdriver.
2. Remove the band by using pliers.

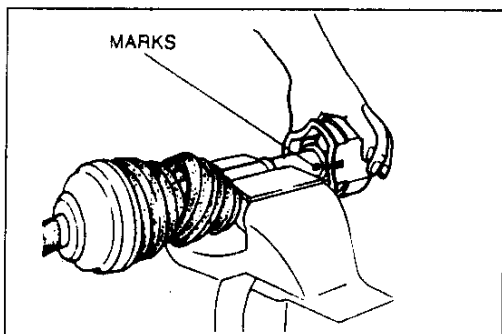

1PE0MX-073

Outer ring

Mark the outer ring and the shaft for proper reassembly.

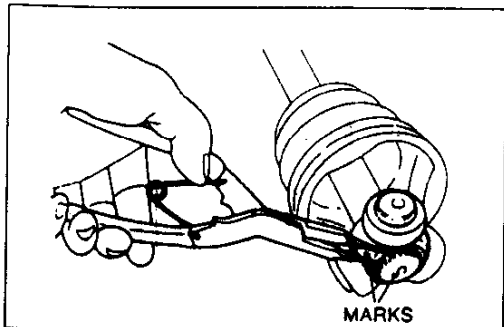

37U0MX-038

Snap ring / Tripod joint

1. Mark the shaft and tripod joint for proper reassembly.
2. Remove the snap ring by using snap-ring pliers.

Caution

- Do not damage the bearings.

3. Drive the tripod joint from the shaft by using a bar and a hammer.

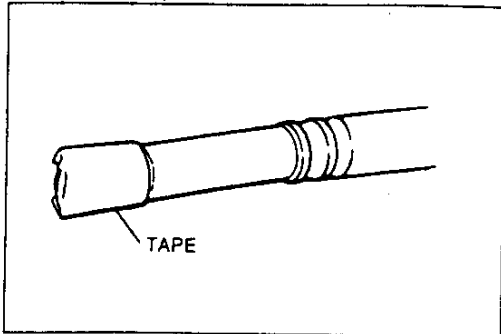

1PE0MX-075

Boot

Caution

- Do not remove the wheel side boot if not necessary.

Wrap the splines of the shaft with tape to prevent damaging the boot.

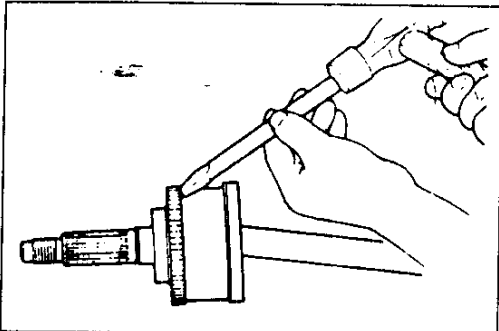

37U0MX-039

ABS sensor rotor

Caution

- Do not remove the sensor rotor if not necessary.
- Do not reuse the sensor rotor if removed.

Tap the sensor rotor off the drive shaft by using a chisel and a hammer.

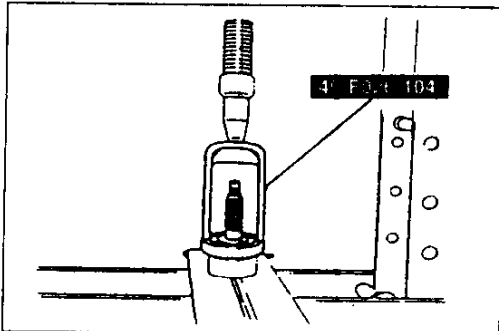

37U0MX-040

Assembly note

ABS sensor rotor

Set a new sensor rotor on the drive shaft and press it on by using the **SST**.

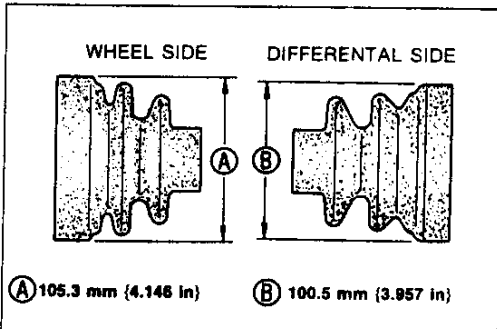

37U0MX-041

Boot

Caution

- The wheel-side and differential side boots are different. Do not misassemble them.

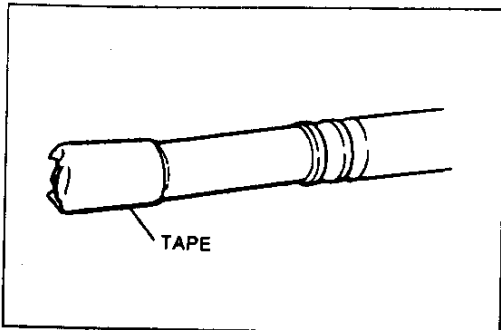

37U0MX-042

1. Wrap the splines of the differential side shaft, and install the boot.

Caution

- Use the specified grease that it is supplied in the boot and joint kits.

2. Fill the wheel side boot with the specified grease.

Grease amount: 100–120g (3.53–4.23 oz)

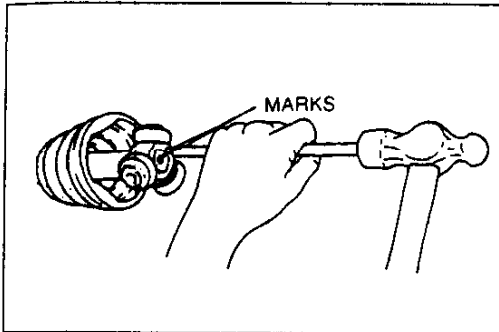

37U0MX-043

Tripod joint / Snap ring

Caution

- Do not damage the bearing.

1. Align the marks and install the tripod joint by using a bar and a hammer.
2. Install a new snap ring by using snap-ring pliers.

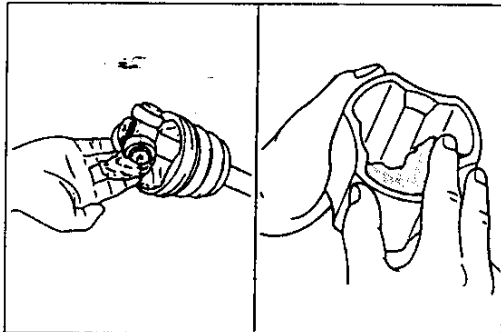

37U0MX-045

Outer ring

Caution

- Use the specified grease that it is supplied in the boot and joint kits.

Fill the outer ring and boot (differential side) with the specified grease.

Grease amount: 170–190g (6.01–6.70 oz)

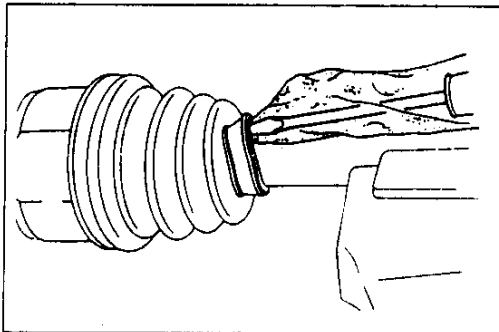

37U0MX-046

Boot band

Caution

- Be sure the boot is not dented or twisted.
- Carefully lift up the small end of the boot to release any trapped air.

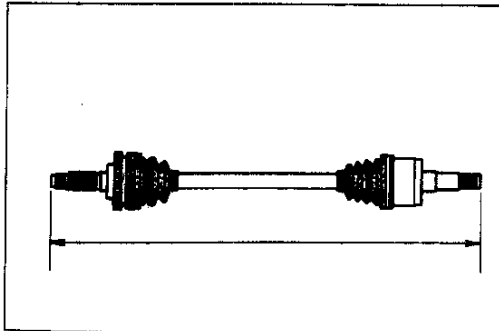

37U0MX-047

1. Measure the length of drive shaft.

Drive shaft length: 791.2–801.2 mm {31.15–31.54 in}

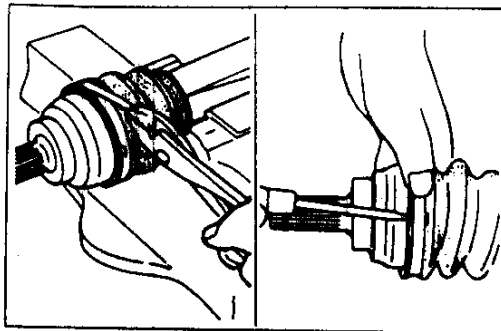

37U0MX-048









2. Fold the new boot band back by pulling on the end with pliers.
3. Lock the end of the boot band by bending the locking tabs.

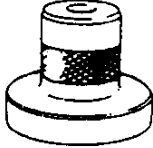

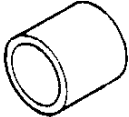
M

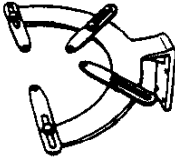
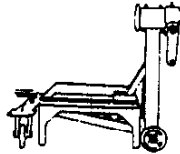
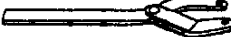
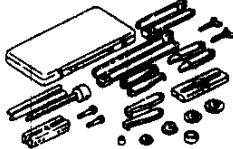
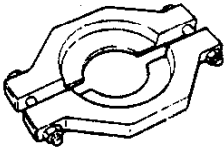
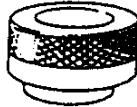
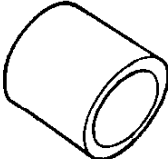
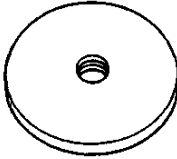
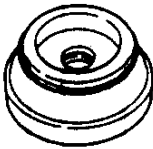
DIFFERENTIAL

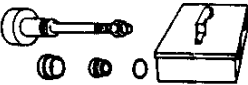
DIFFERENTIAL

PREPARATION SST

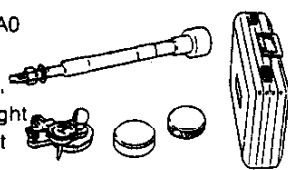
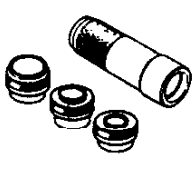
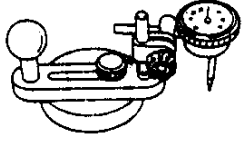
<p>49 V001 795 Installer, oil seal</p> 	<p>For installation of oil seal (companion flange)</p>	<p>49 B001 795 Installer, oil seal</p> 	<p>For installation of oil seal (side bearing)</p>
<p>49 U027 003 Installer, oil seal</p> 	<p>For installation of oil seal (side bearing)</p>	<p>49 B001 797 Handle (Part of 49 B001 795)</p> 	<p>For installation of oil seal (side bearing)</p>
<p>49 M005 561 Hanger, differential carrier</p> 	<p>For disassembly / assembly of differential</p>	<p>49 0107 680A Stand, engine</p> 	<p>For disassembly / assembly of differential</p>
<p>49 S120 710 Holder, coupling flange</p> 	<p>For removal / installation of companion flange nut</p>	<p>49 0839 425C Puller set, bearing</p> 	<p>For Removal of companion flange and side bearing</p>
<p>49 H027 002 Remover, bearing</p> 	<p>For removal of rear bearing</p>	<p>49 UB71 525 Installer, bearing</p> 	<p>For installation of side bearing</p>
<p>49 J027 002 Collar</p> 	<p>For adjustment of pinion height</p>	<p>49 J027 001 Installer, bearing</p> 	<p>For installation of rear bearing race</p>
<p>49 F027 007 Attachment φ 72</p> 	<p>For installation of front bearing race</p>	<p>49 8531 567 Collar A (Part of 49 8531 565)</p> 	<p>For adjustment of pinion height</p>
<p>49 8531 565 Pinion model</p> 	<p>For adjustment of pinion height</p>	<p>49 0660 555 Gauge block (Part of 49 F027 0A0)</p> 	<p>For adjustment of pinion height</p>

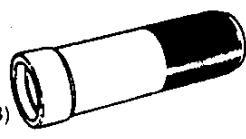
<p>49 F027 0A0</p> <p>Gauge set, pinion height adjustment</p> 	<p>For adjustment of pinion height</p>	<p>49 F401 330B</p> <p>Installer set, bearing</p> 	<p>For installation of rear bearing</p>
<p>49 0727 570</p> <p>Gauge body, pinion height (Part of 49 F027 0A0)</p> 	<p>For adjustment of pinion height</p>	<p>49 G030 338</p> <p>Attachment E</p> 	<p>For installation of rear bearing</p>
<p>49 F401 331</p> <p>Body (Part of 49 F401 330B)</p> 	<p>For installation of rear bearing</p>	37U0MX-049	

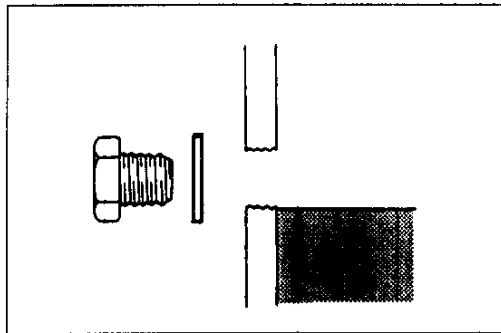

37U0MX-050

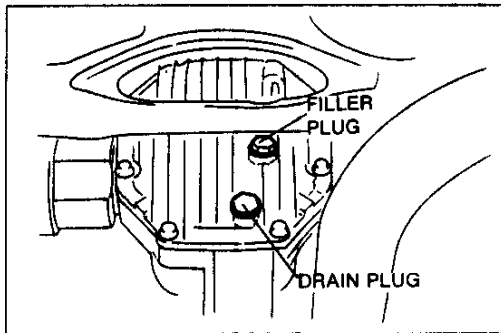

37U0MX-051

DIFFERENTIAL OIL Inspection

Caution

- Position the vehicle level.

1. Remove the filler plug.
2. Verify that the oil is at the bottom of the filler plug hole. If it is low, add the specified oil.
3. Install a new washer and the filler plug.

Tightening torque:

39–53 N·m {4.0–5.5 kgf·m, 29–39 ft·lbf}

Replacement

1. Remove the filler and drain plugs.
2. Drain the differential oil into a suitable container.
3. Wipe the plugs clean.
4. Install a new washer and the drain plug.

Tightening torque:

39–53 N·m {4.0–5.5 kgf·m, 29–39 ft·lbf}

5. Add the specified oil from the filler plug hole until it reaches the bottom of the hole.

Specified oil

Type

Above – 18°C {0°F}: API GL-4 or 5, SAE 90

Below – 18°C {0°F}: API GL-4 or 5, SAE 80

Capacity: 1.30 L {1.38 US qt, 1.14 Imp qt}

6. Install a new washer and the filler plug.

Tightening torque:

39–53 N·m {4.0–5.5 kgf·m, 29–39 ft·lbf}

29U0MX-060

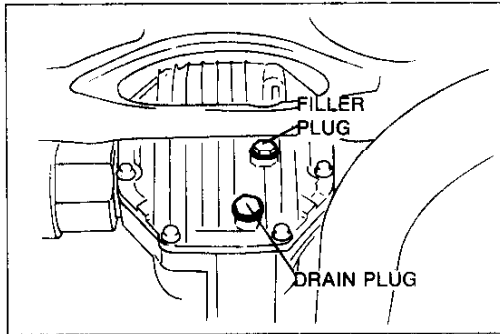

37U0MX-05

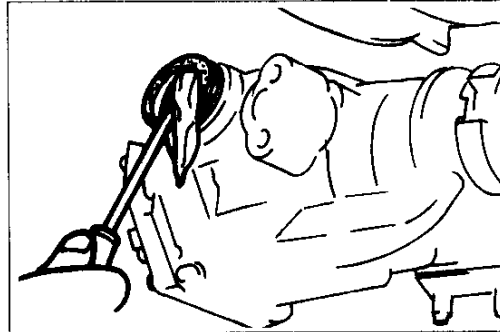

37U0MX-05

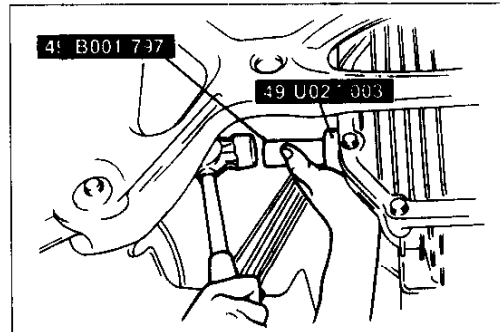

37U0MX-05

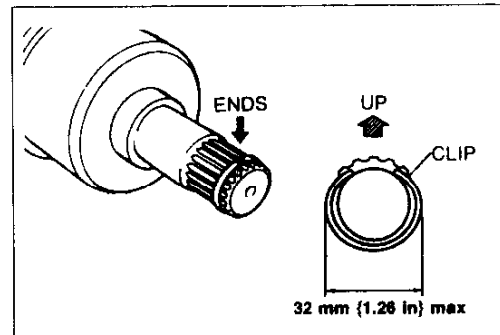

37U0MX-05

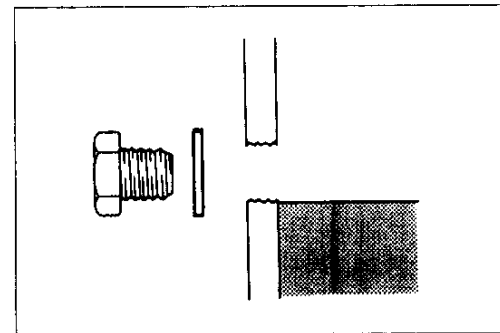

37U0MX-05

OIL SEAL

Replacement

Oil seal (side bearing)

1. Remove the filler and drain plugs.
2. Drain the differential oil into a suitable container.
3. Wipe the plugs clean.
4. Install a new washer and the drain plug.

Tightening torque:

39–53 N·m {4.0–5.5 kgf·m, 29–39 ft·lbf}

5. Remove the drive shaft. (Refer to page M-15.)
6. Remove the clip from the drive shaft.

Caution

- Use a screwdriver covered with a rag to prevent damaging the differential carrier.

7. Pry out the oil seal.

8. Apply clean differential oil to the lip of a new oil seal.
9. Install the oil seal by using the **SST**.

Caution

- Measure the outside diameter of the clip after installing it on the shaft. Replace the clip if it exceeds the specification.

10. Install a new clip onto the drive shaft.

Caution

- Do not damage the oil seal.

11. Install the drive shaft with the ends of the clip facing upward.
12. Verify that the drive shaft is seated into the side gear by pulling it outward by hand. It should not come out.
13. Add the specified oil through the filler plug hole until it reaches the bottom of the hole.

Specified oil

Type

Above – 18°C {0°F}: API GL-4 or 5, SAE 90

Below – 18°C {0°F}: API GL-4 or 5, SAE 80

Capacity: 1.30 L {1.38 US qt, 1.14 Imp qt}

14. Install a new washer and the filler plug.

Tightening torque:

39–54 N·m {4.0–5.5 kgf·m, 29–40 ft·lbf}

15. Check for oil leakage.

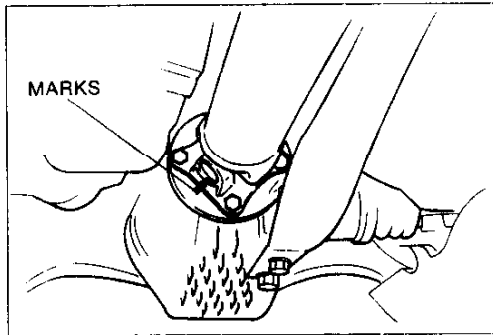

37U0MX-0i7

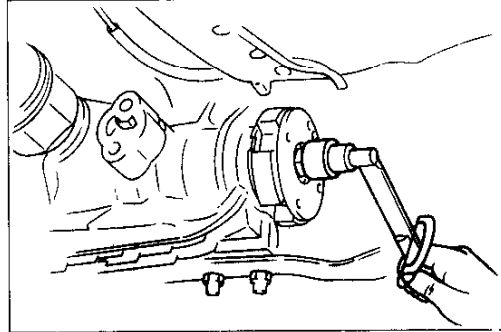

37U0MX-0i7

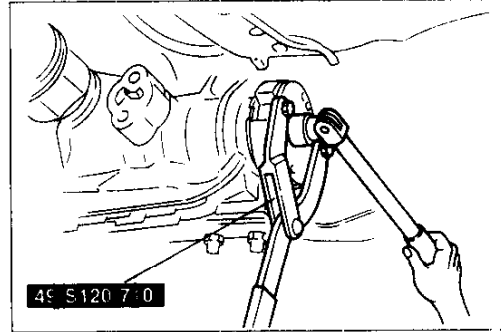

37U0MX-0i8

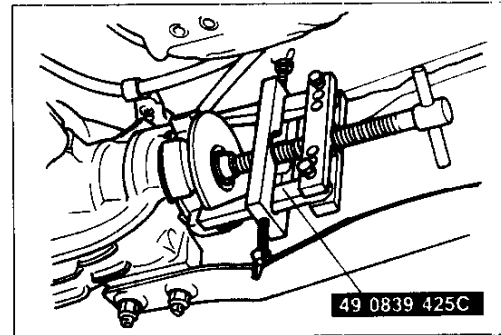

37U0MX-0i9

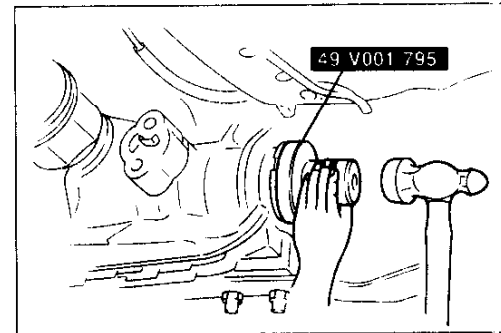

37U0MX0i9

Oil seal (companion flange)

1. Remove the filler and drain plugs.
2. Drain the differential oil into a suitable container.
3. Wipe the plugs clean.
4. Install a new washer and the drain plug.

Tightening torque:

40–53 N·m {4.0–5.5 kgf·m, 29–39 ft·lbf}

5. Mark the propeller shaft and differential companion flange for proper reinstallation.
6. Remove the nuts and bolts and remove the propeller shaft.
7. Measure and record the rotation starting torque of the drive pinion.

Note

- Measure the torque within the range of the drive pinion backlash.

8. Using the **SST** to hold the companion flange, remove the nut.

9. Use the **SST** to remove the companion flange.
10. Remove the oil seal by using a screwdriver.

11. Apply clean differential oil to the lip of the new oil seal.
12. Install the oil seal by using the **SST**.

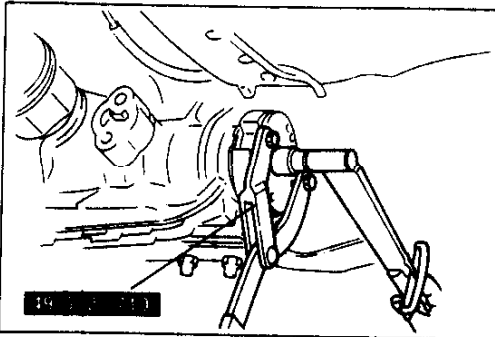

37U0MX-060

13. Using the **SST**, hold the companion flange and tighten the new companion flange nut to the specified torque.

Tightening torque:

128–284 N·m {13.0–29.0 kgf·m, 94.1–209 ft·lbf}

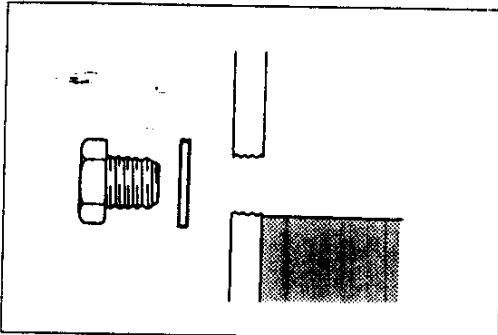

37U0MX-061

14. Loosen the nut. Retighten it to get the starting torque recorded in Step 7.
 15. Add the specified oil through the filler plug hole until it reaches the bottom of the hole.

Specified oil**Type**

Above – 18°C {0°F}: API GL-4 or 5, SAE 90

Below – 18°C {0°F}: API GL-4 or 5, SAE 80

Capacity: 1.30 L {1.38 US qt, 1.14 imp qt}

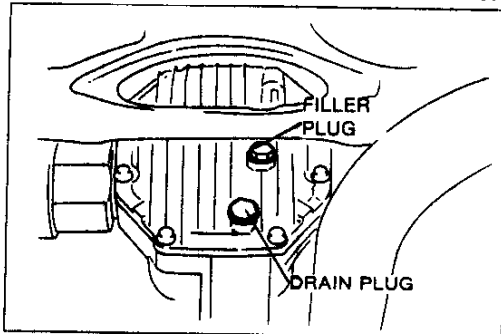

37U0MX-062

16. Install a new washer and the filler plug.

Tightening torque:

40–53 N·m {4.0–5.5 kgf·m, 29–39 ft·lbf}

17. Check for oil leakage.

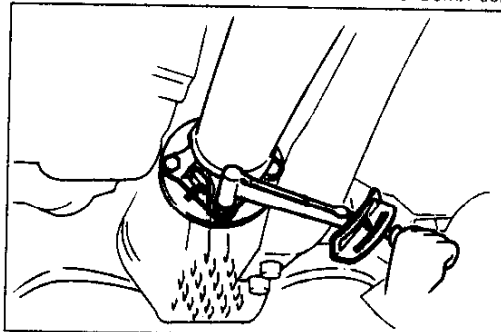

37U0MX-063

18. Align the marks and install the propeller shaft.

Tightening torque:

49–58 N·m {5.0–6.0 kgf·m, 37–43 ft·lbf}

DIFFERENTIAL (TORQUE SENSING LSD)

Removal / Installation

- 1 Remove the exhaust pipe. (Refer to Section F.)
- 2 Remove in the order shown in the figure, referring to **Removal Note**.
- 3 Install in the reverse order of removal, referring to **Installation Note**.
- 4 After installation, check the rear wheel alignment. (Refer to Section R.)
- 5 Refill the differential with the specified type and amount of oil. (Refer to page M-23.)
- 6 Install the exhaust pipe. (Refer to Section F.)

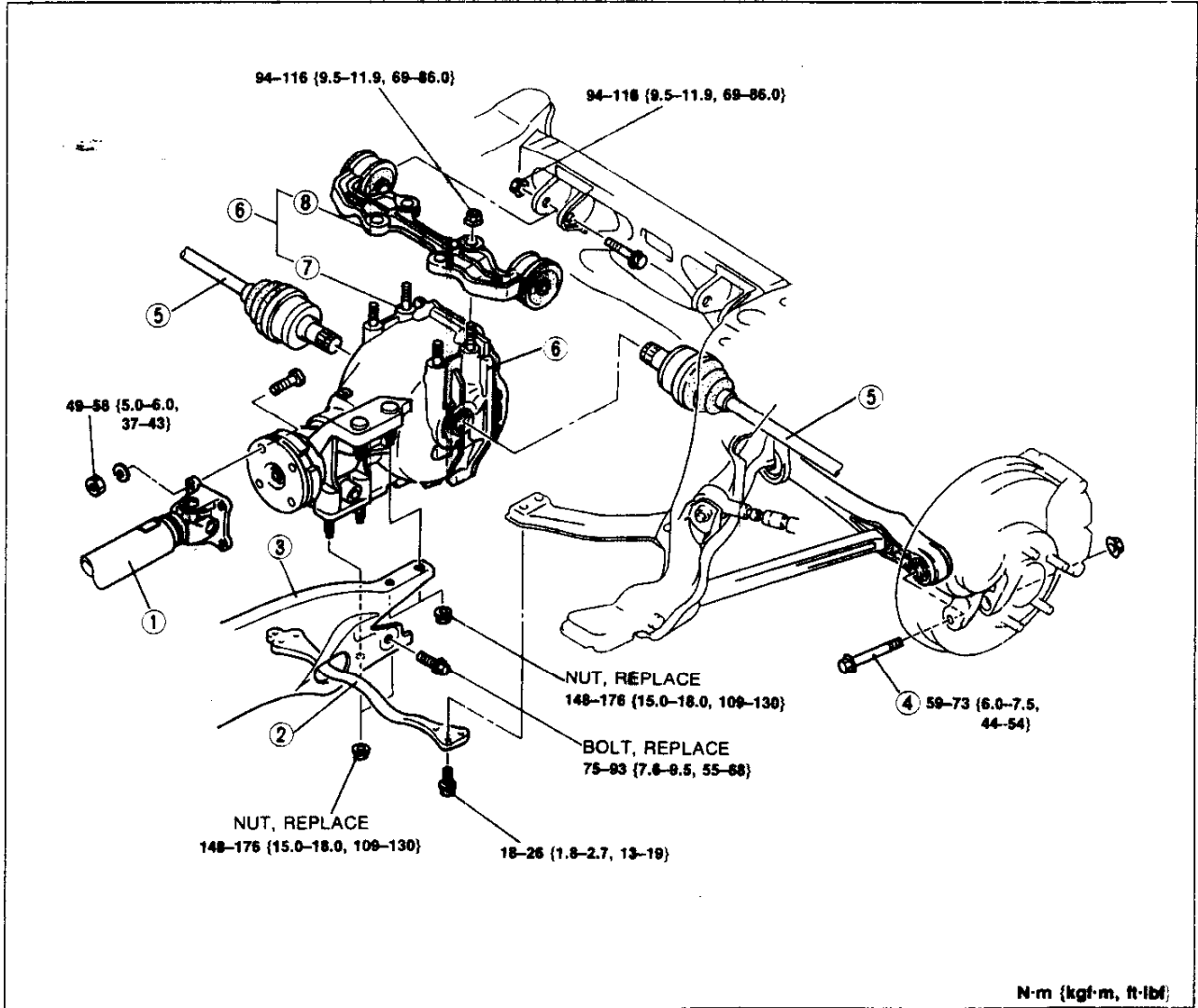

37U0MX-064

- | | |
|--|---|
| <p>1. Propeller shaft
Removal Note page M-28
Service Section L
Installation Note page M-29</p> <p>2. Tunnel reinforcement bracket</p> <p>3. Power plant flame
Service Section J</p> <p>4. Bolt (I-arm)</p> | <p>5. Drive shaft
Removal Note page M-28
Installation Note page M-28</p> <p>6. Differential assembly
Removal Note page M-28</p> <p>7. Differential
Disassembly / Inspection /
Assembly page M-30</p> <p>8. Differential mount
Inspect bushing for wear and damage</p> |
|--|---|

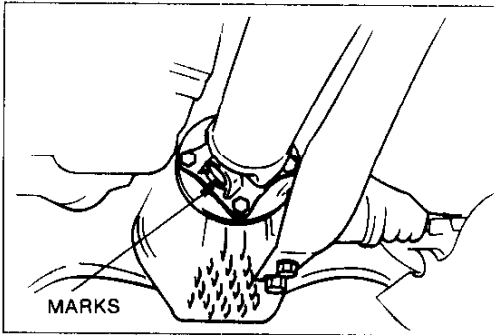

37U0MX-065

Removal note Propeller shaft

1. Mark the propeller shaft and differential companion flange for proper reassembly.
2. Remove the nuts and bolts and remove the propeller shaft.

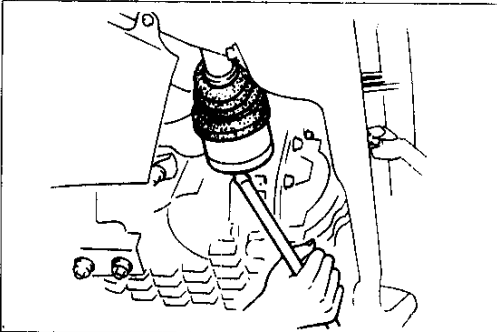

37U0MX-066

Drive shaft

Caution

- Do not damage the oil seal.

1. Remove the drive shaft from the differential by using a pry bar.
2. Pull outward on the rear hub support and disc plate to disconnect the drive shaft from the differential.

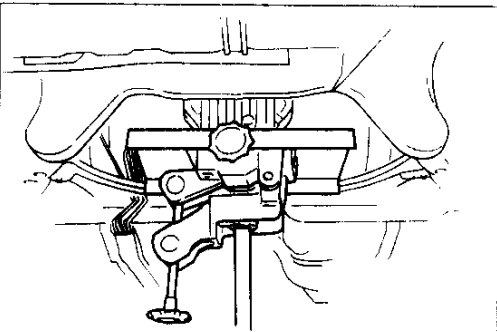

37U0MX-067

Differential assembly

1. Support the differential on a jack.
2. Remove the differential.

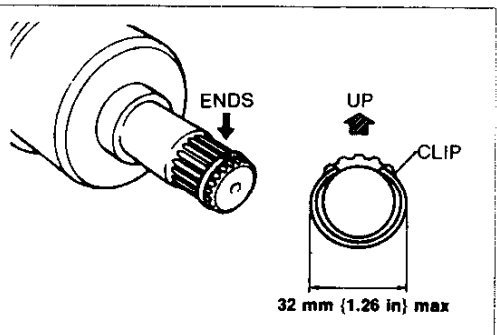

37U0MX-068

Installation note

Drive shaft

Caution

- Do not excessively spread the clip when installing it.
- Measure the outside diameter of the clip after installing it on the shaft. Replace the clip if it exceeds the specification.

1. Install a new clip on the drive shaft.

Caution

- Do not damage the oil seal.

2. With the ends of the clip facing upward, push the drive shaft into the differential.

Note

- After installation, pull outward on the tripod joint outer ring and verify that the drive shaft is held by the clip.

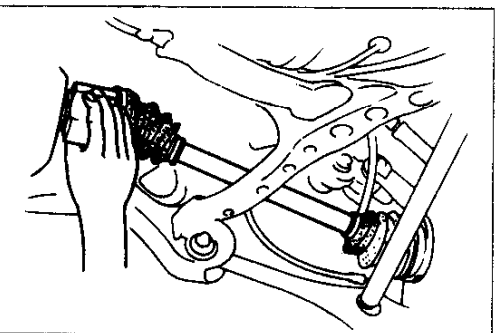

37U0MX-069

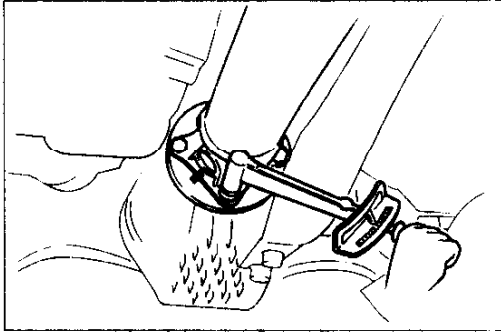

37U0MX 073

Propeller shaft

Align the marks and install the propeller shaft.

Tightening torque:

49–59 N·m {5.0–6.0 kgf·m, 37–43 ft·lb}

M

DIFFERENTIAL

Disassembly / Inspection

1. Disassemble in the order shown in the figure, referring to **Disassembly Note**.
2. Inspect all parts and repair or replace as necessary.

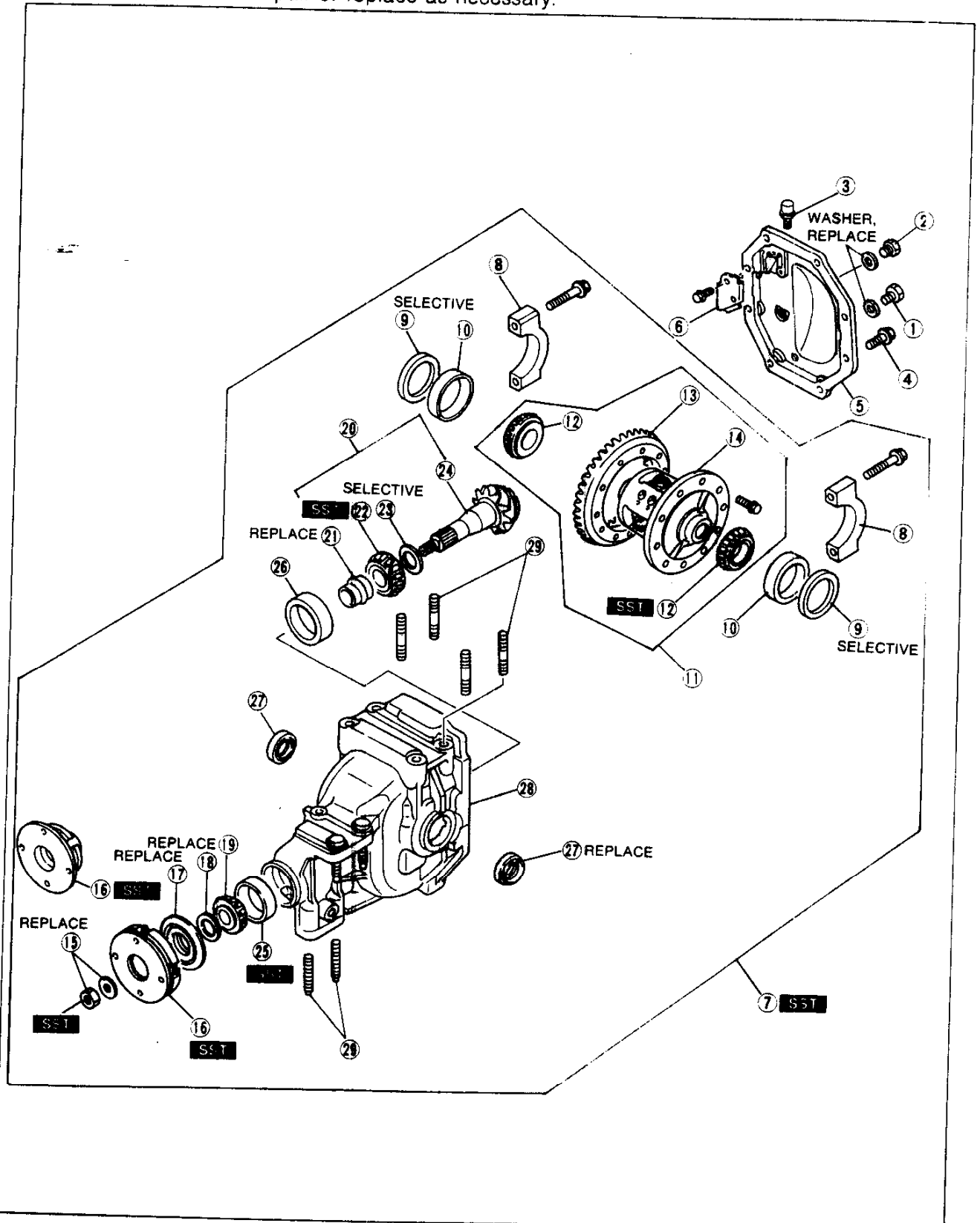

- 1. Drain plug
- 2. Filler plug
- 3. Breather
Inspect for clogging
- 4. Carrier bolt
- 5. Rear cover
- 6. Baffle
- 7. Differential gear assembly
Disassembly Note below
- 8. Bearing cap
Disassembly Note page M-32
- 9. Adjustment shim
Disassembly Note page M-32
- 10. Side bearing race
Disassembly Note page M-32
Inspect for cracks and damage
- 11. Gear case assembly
- 12. Side bearing
Disassembly Note page M-32
Inspect for damage and rough rotation
- 13. Ring gear
Inspect gear teeth for wear and cracks
- 14. Gear case (Torsen LSD assembly)
Inspect gear teeth for wear and cracks
Inspect housing for cracks and damage
- 15. Companion flange nut and washer
Disassembly Note page M-32
- 16. Companion flange
Disassembly Note page M-33
- 17. Oil seal (companion flange)
- 18. Spacer
- 19. Front bearing
Inspect for damage and rough rotation
- 20. Drive pinion assembly
Disassembly Note page M-33
- 21. Collapsible spacer
- 22. Rear bearing
Disassembly Note page M-33
Inspect for damage and rough rotation
- 23. Spacer
- 24. Drive pinion
Inspect splines for wear and damage
Inspect gear teeth for wear and cracks
- 25. Front bearing race
Disassembly Note page M-33
Inspect for cracks and damage
- 26. Rear bearing race
Disassembly Note page M-33
Inspect for cracks and damage
- 27. Oil seal (side bearing)
- 28. Differential carrier
Inspect for cracks and damage
- 29. Stud

37U0MX-071

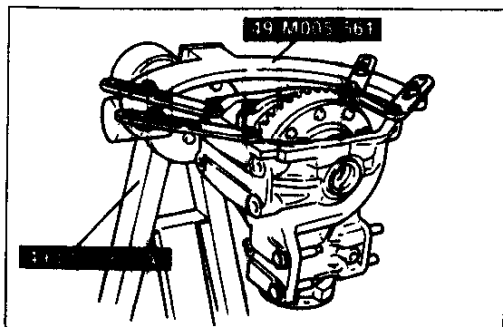

37U0MX-072

Disassembly note
Differential gear assembly

Mount the differential gear assembly on the **SSTs**.

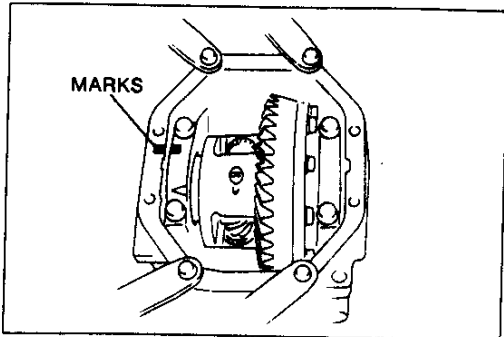

37U0MX-073

Bearing cap

1. Mark the bearing caps and differential carrier for proper reassembly.
2. Remove the bearing caps.

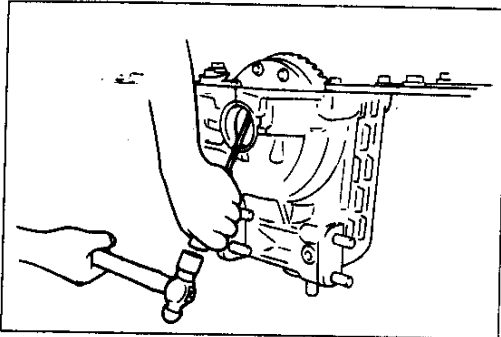

37U0MX-074

Adjustment shim and side bearing race

Caution

- Do not damage the oil seal, bearing race, or differential carrier.
- Do not push against the bearing races.

1. Drive out the an adjustment shim. Remove the gear case assembly, the side bearing races, and the other adjustment shim.

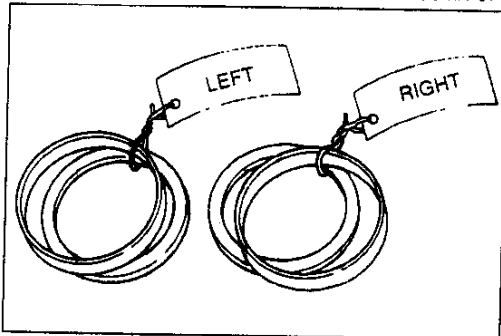

37U0MX-075

2. Tag the right and left adjustment shims and side bearing races for proper reassembly.

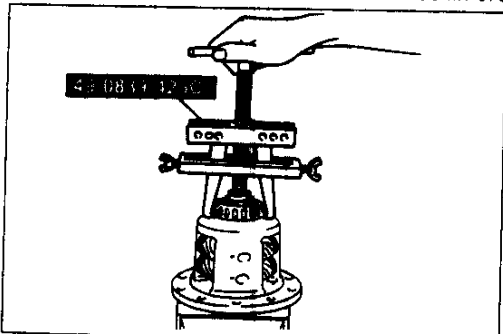

29U0MX-090

Side bearing

Caution

- Mark the side bearings for right and left side.
- Use protective plates in a vise.

Remove the side bearings from the gear case by using the **SST**.

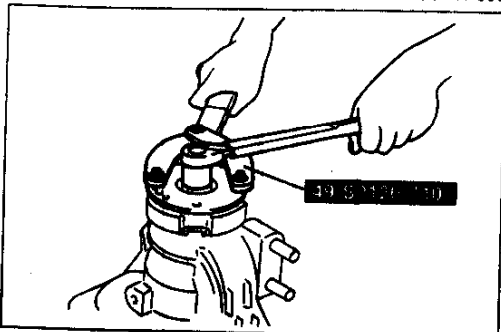

29U0MX-091

Companion flange nut

Hold the companion flange by using the **SST** and remove the nut.

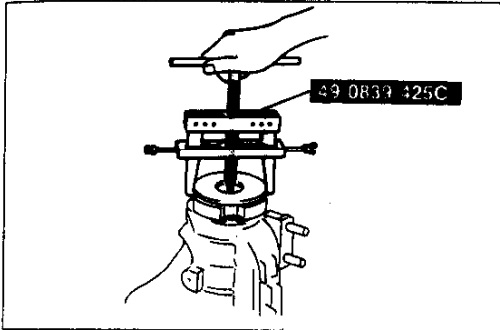

37U0MX-076

Companion flange

Remove the companion flange by using the **SST**.

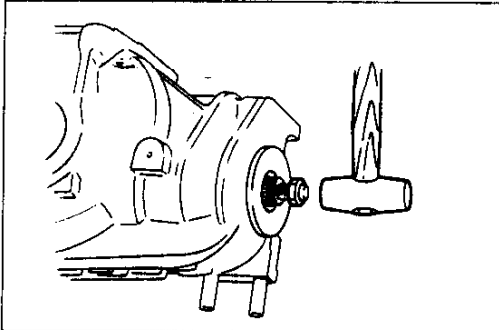

29U0MX-093

Drive pinion assembly

1. Turn a used nut onto the drive pinion until it is about flush with the end of the shaft.
2. Tap the nut by using a brass hammer to drive the pinion assembly out of the differential carrier.

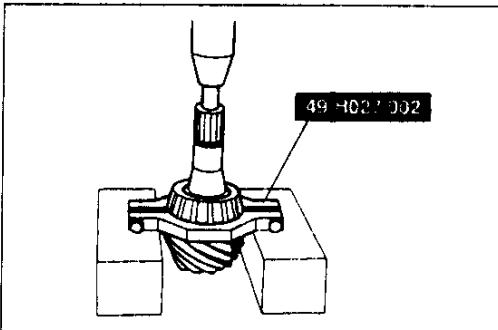

29U0MX-094

Rear bearing**Caution**

- Support the drive pinion by hand so that it will not fall.

Remove the rear bearing by using the **SST**.

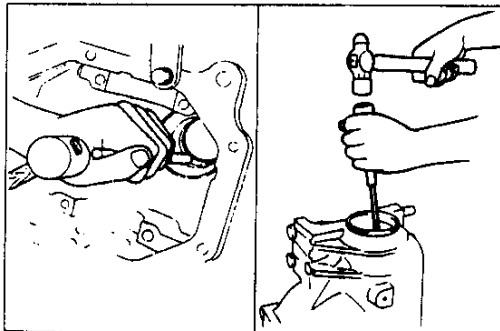

29U0MX-095

Front bearing race and rear bearing race

Remove the bearing races by alternately tapping the sides of the races at the grooves in the differential carrier.

M

DIFFERENTIAL

Assembly

Caution

- Install the rear cover within 10 minutes after applying sealant. Allow the sealant to set at least 30 minutes after installation before filling the differential with the specified oil.

Assemble in the other shown in the figure, referring to **Assembly Note**.

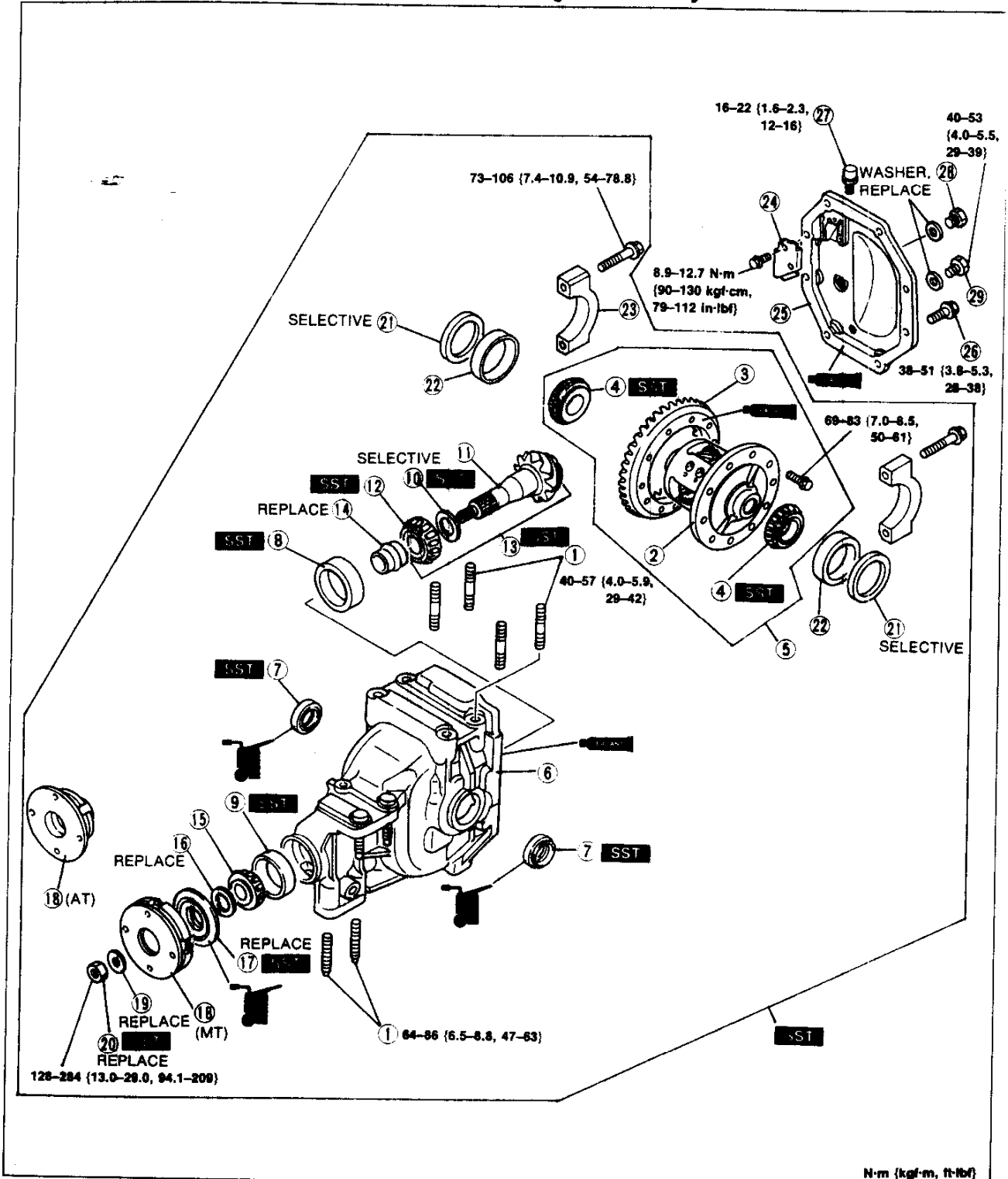

N-m {kgf-m, ft-lbf}

37UOMX-077

- | | |
|------------------------------------|-----------|
| 1. Stud | |
| 2. Gear case (Torsen LSD assembly) | |
| 3. Ring gear | |
| Assembly Note | page M-35 |
| 4. Side bearing | |
| Assembly Note | page M-35 |
| 5. Gear case assembly | |
| 6. Differential carrier | |
| 7. Oil seal (side gear) | |
| Assembly Note | page M-35 |
| 8. Rear bearing race | |
| Assembly Note | page M-36 |
| 9. Front bearing race | |
| Assembly Note | page M-36 |
| 10. Spacer | |
| Assembly Note | page M-36 |
| 11. Drive pinion | |
| 12. Rear bearing | |
| Assembly Note | page M-37 |
| 13. Drive pinion assembly | |
| Assembly Note | page M-38 |
| 14. Collapsible spacer | |
| 15. Front bearing | |
| 16. Spacer | |
| 17. Oil seal (companion flange) | |
| Assembly Note | page M-38 |
| 18. Companion flange | |
| Assembly Note | page M-38 |
| 19. Washer | |
| 20. Companion flange nut | |
| Assembly Note | page M-39 |
| 21. Adjustment shim | |
| Assembly Note | page M-39 |
| 22. Side bearing race | |
| 23. Bearing cap | |
| Assembly Note | page M-40 |
| 24. Baffle | |
| 25. Rear cover | |
| 26. Carrier bolt | |
| 27. Breather | |
| 28. Filler plug | |
| 29. Drain plug | |

37U0MX-178

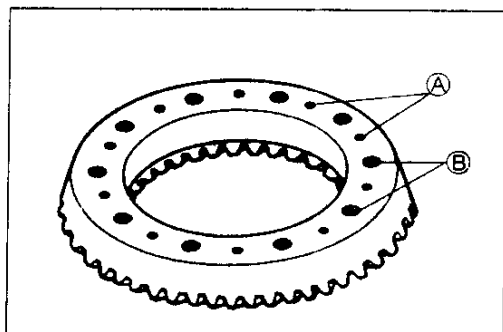

37U0MX-079

Assembly note
Ring gear

Note

- Apply approx. 0.04 cc {0.0024 cu in} of thread-locking compound at each point.

1. Apply thread-locking compound to bolt threads A and points B of the gear back face.
2. Install the ring gear onto the gear case.

Tightening torque:

69-83 N·m {7.0-8.5 kgf·m, 50-61 ft-lbf}

Side bearing

Caution

- Do not mistake the right and left bearings
- Press the side bearings on by using the SST.

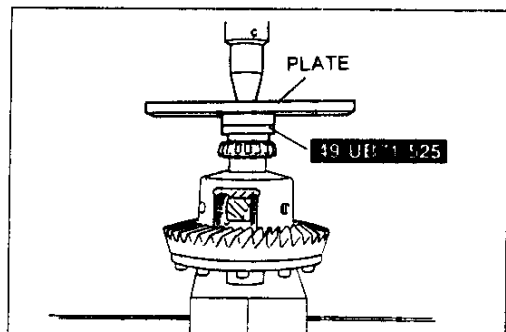

37U0MX-080

Oil seal

1. Apply differential oil to the lips of the new seals.
2. Install the seals by using the SST.

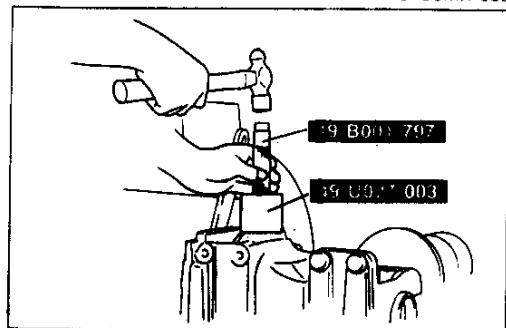

37U0MX-081

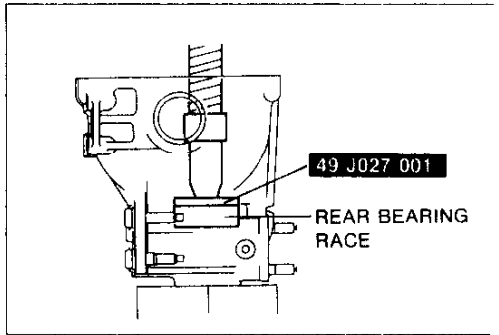

29U0MX-101

Rear bearing race

Install the rear bearing race by using the **SST**.

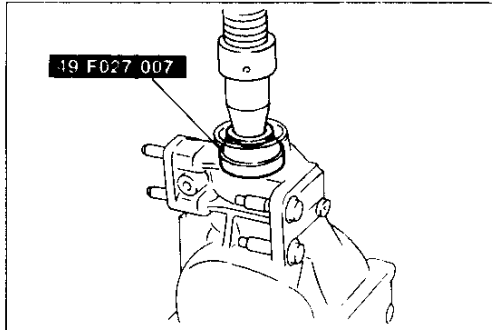

29U0MX-103

Front bearing race

Install the front bearing race by using **SST**.

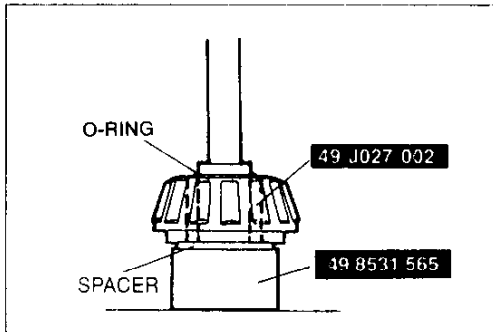

29U0MX-105

Spacer (adjustment of pinion height)

Note

- Use the spacer that was removed.
- Install the spacer with the beveled side facing the drive pinion.

1. Install the spacer, rear bearing and O-ring onto the **SST** as shown in the figure.
2. Install this assembly into the differential carrier.

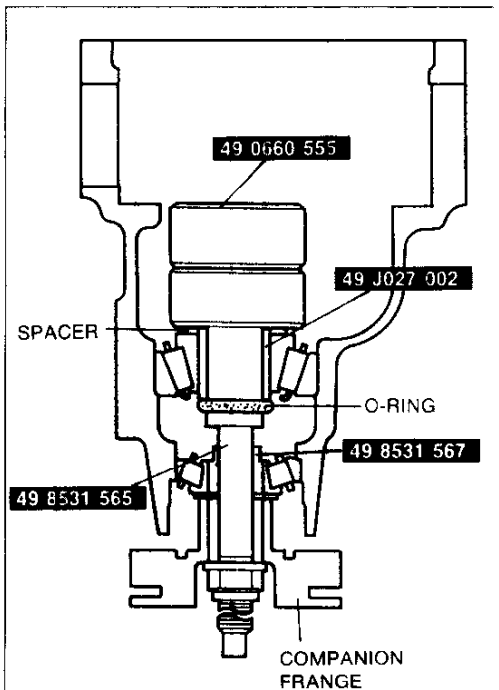

29U0MX-107

3. Install the **SST** (collar), front bearing, companion flange, washer and nut.
4. Tighten the nut just enough so that the companion flange can still be turned by hand.
5. Place the **SST** (gauge block) atop the **SST** (pinion model).

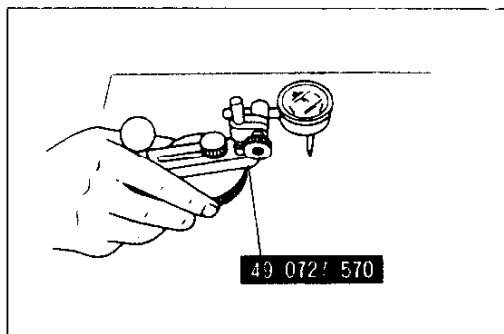

37U0MX-012

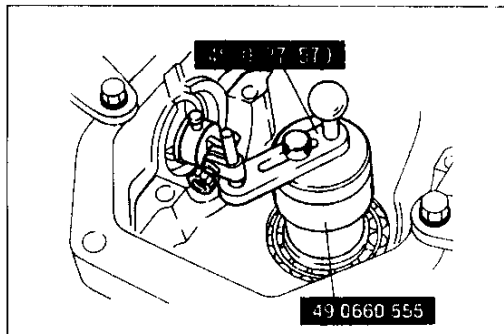

37U0MX-013

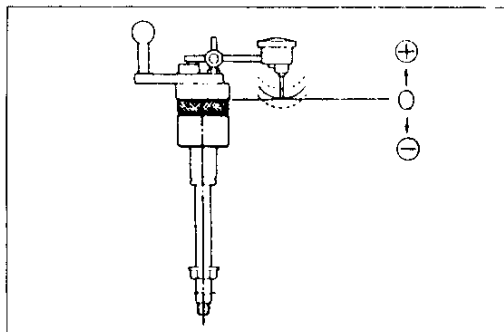

29U0MX-110

6. Place the **SST** on a surface plate and set the dial indicator to Zero.

7. Set the **SST** (gauge body) atop the **SST** (gauge block).
 8. Place the feeler of the dial indicator so that it contacts the side bearing saddle in the carrier. Measure the lowest position on the left and right sides of the carrier.

9. Add the two (left and right) values obtained in Step 8 and divide the total by 2.

Specification : 0 mm {0 in}

Mark	Thickness	Mark	Thickness
08	3.08 mm {0.1213 in}	29	3.29 mm {0.1295 in}
11	3.11 mm {0.1224 in}	32	3.32 mm {0.1307 in}
14	3.14 mm {0.1236 in}	35	3.35 mm {0.1319 in}
17	3.17 mm {0.1248 in}	38	3.38 mm {0.1331 in}
20	3.20 mm {0.1260 in}	41	3.41 mm {0.1343 in}
23	3.23 mm {0.1271 in}	44	3.44 mm {0.1354 in}
26	3.26 mm {0.1283 in}	47	3.47 mm {0.1366 in}

37U0MX-014

Note

● Spacers are available in increments of 0.03 mm {0.002 in}. Select the spacer thickness that is closest to that necessary.

10. If not within specification, adjust the pinion height by installing the proper spacer.

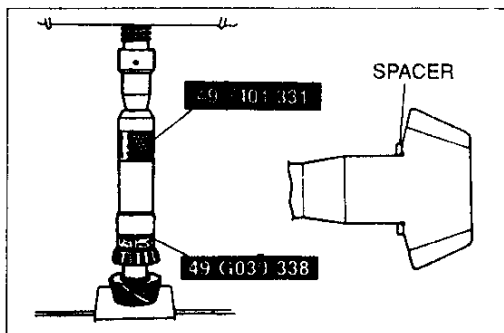

37U0MX-015

Rear bearing

Note

- Install the spacer selected by the adjustment of pinion height.
- Install the spacer with the beveled side facing the drive pinion.
- Press on until the force required suddenly increases.

Press on the spacer and rear bearing by using the **SST**.

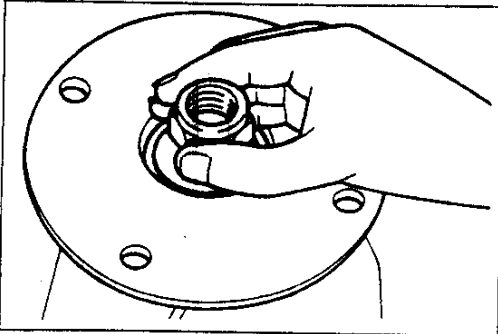

29U0MX-113

Drive pinion assembly (adjustment of drive pinion preload)

Note

- Perform the following procedure without the companion flange oil seal installed.

1. Apply a light coat of grease to the end face of the companion flange.
2. Install the drive pinion assembly in the differential carrier.
3. Install a new collapsible spacer, front bearing, new front spacer, companion flange, and new washer.
4. Temporarily tighten the new companion flange nut.
5. Hold the companion flange by using the **SST** and tighten the nut.

Tightening torque: 128 N·m {13 kgf·m, 94.1 ft·lbf}

6. Turn the companion flange several turns by hand to seat the bearings.

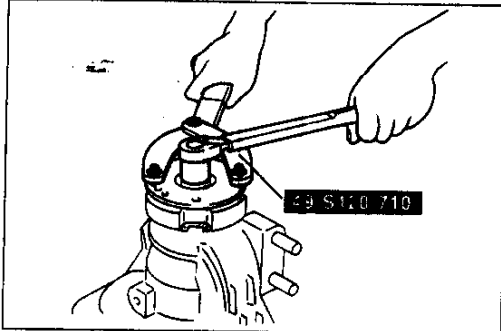

37U0MX-086

7. Measure the drive pinion preload.

Note

- Record the tightening torque for proper reinstallation of the companion flange.

8. Adjust the preload by tightening the nut and record the tightening torque.

Drive pinion preload:

1.3–1.8 N·m {13–18 kgf·cm, 12–15 in·lbf}

Tightening torque:

128–284 N·m {13.0–29.0 kgf·m, 94.1–209 ft·lbf}

9. If the specified preload is not obtained after tightening the nut to the maximum torque, replace the collapsible spacer with a new one.
10. Remove the nut, washer, and companion flange.

Oil seal (companion flange)

1. Apply clean differential oil to the lip of the new oil seal.
2. Install the oil seal by using the **SST**.

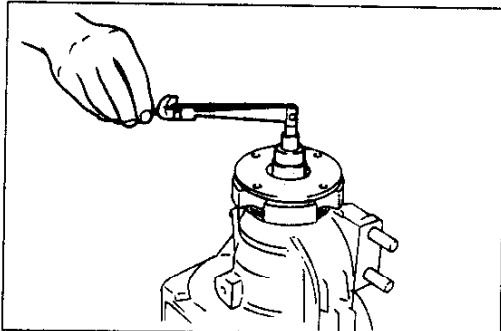

37U0MX-087

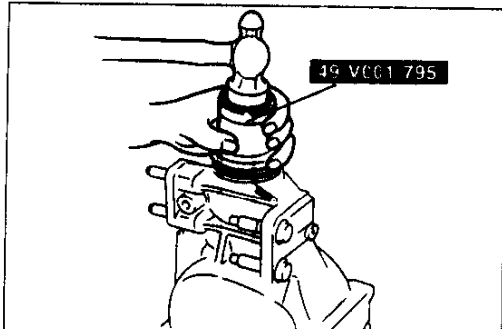

37U0MX-089

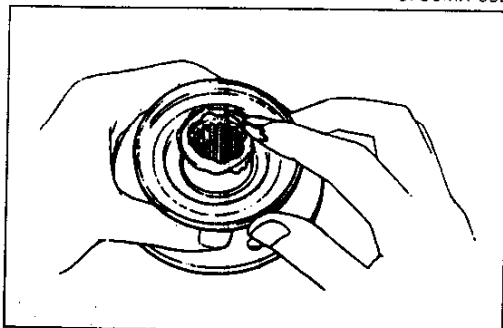

29U0MX-117

Companion flange

Apply a light coat of grease to the end face of the companion flange.

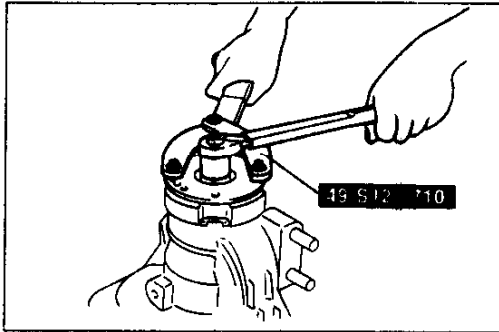

37U0MX-090

Companion flange nut

1. Using the **SST**, hold the companion flange and tighten the nut to the tightening torque recorded in "adjustment of drive pinion preload."
2. Verify that the drive pinion preload is within specification.

Drive pinion preload:

1.3–1.8 N·m {13–18 kgf·cm, 12–15 in·lbf}

Adjustment shims (adjustment of ring gear backlash)

1. Install the bearing races and measure the side bearing and gear case assembly height **A** as shown.

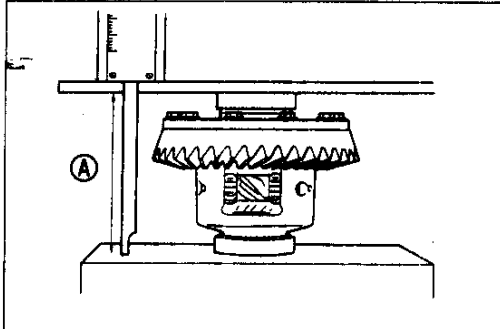

37U0MX-091

Standard height:

158.4–159.6 mm {6.24–6.28 in}

2. Measure the width **B** of the inside of the differential carrier as shown.

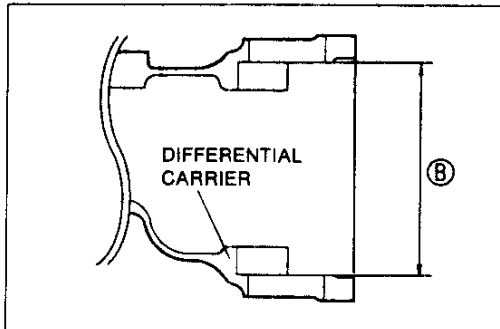

29U0MX-120

Standard width:

170.9–171.1 mm {6.729–6.736 in}

3. The right and left total adjustment shims thickness **C** is determined by the following.

C mm = B–A mm + (0.01–0.03 mm)

C in = B–A in + (0.0004–0.0012 in)

4. If **C** is equal to the total thickness of the removed right and left adjustment shims, reuse them.
5. If **C** is not equal to the removed shims, or when the shims are to be replaced, select and use the shims from the following table.

Note

- **Install the same thickness adjustment shim on both sides.**

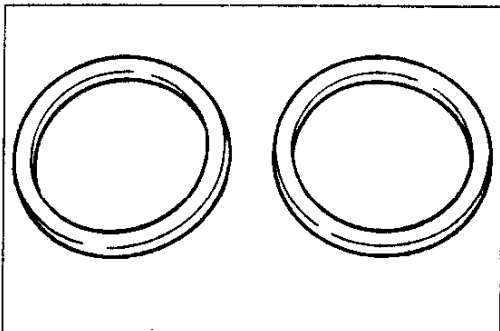

Identifica- tion mark	Thickness	Identifica- tion mark	Thickness
550	5.50 mm {0.2165 in}	605	6.05 mm {0.2382 in}
560	5.60 mm {0.2205 in}	610	6.10 mm {0.2402 in}
565	5.65 mm {0.2224 in}	615	6.15 mm {0.2421 in}
570	5.70 mm {0.2244 in}	620	6.20 mm {0.2441 in}
575	5.75 mm {0.2264 in}	625	5.25 mm {0.2461 in}
580	5.80 mm {0.2283 in}	630	6.30 mm {0.2480 in}
585	5.85 mm {0.2303 in}	635	6.35 mm {0.2500 in}
590	5.90 mm {0.2323 in}	640	6.40 mm {0.2520 in}
595	5.95 mm {0.2343 in}	650	6.50 mm {0.2559 in}
600	6.00 mm {0.2362 in}	–	–

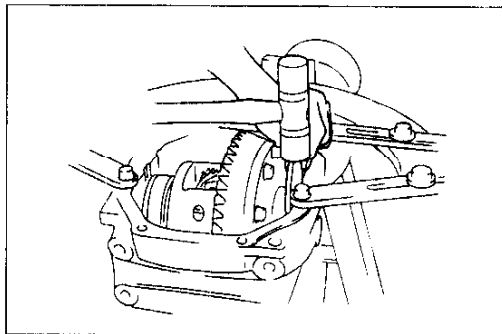

37U0MX-092

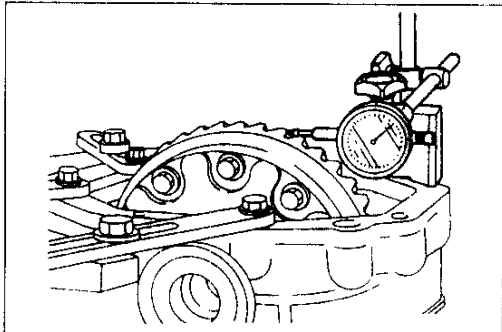

29U0MX-122

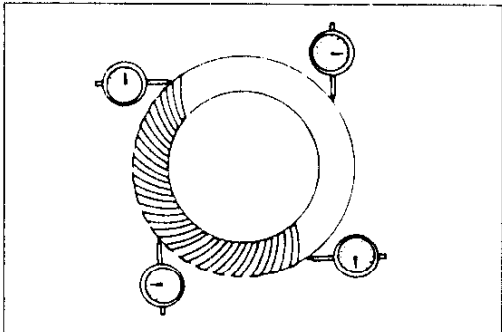

29U0MX-123

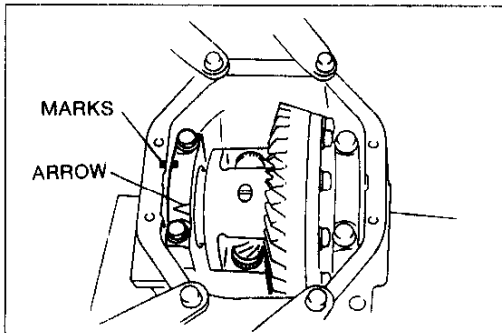

37U0MX-093

Caution

- Do not interchange the right and left side bearing races.
- When reusing the adjustment shims, do not interchange the right and left shims.

6. Install the side bearing races, gear case assembly and one side adjustment shim(s) into the differential carrier.
7. Tap the other side adjustment shim(s) in by using a plastic hammer.
8. Install the bearing caps and loosely tighten the bolts.
9. Mark the ring gear at four points at **approx. 90 degrees** intervals. Mount a dial indicator to the carrier so that the feeler comes into contact at a right angle with one of the ring gear teeth at a point marked.
10. Measure the ring gear backlash.

Standard backlash:

0.09–0.11 mm {0.0035–0.0043 in}

11. Measure the backlash at the three other marked points, and verify that the minimum backlash is more than **0.05 mm {0.002 in}** and the difference between the maximum and minimum is less than **0.07 mm {0.0028 in}**.
12. If the backlash is not within specification, adjust it by inserting an appropriate adjustment shim at both sides of the carrier.

Note

- When replacing the right adjustment shim with a thinner one, replace the left with an equally thicker one.

Bearing caps**Note**

- After installing the bearing caps, check the drive pinion and ring gear tooth contact. (Refer to page M-41.)

Caution

- Do not interchange the right and left bearing caps.

1. Match the marks and face the arrow on the caps outward.
2. Tighten the bolts to the specified torque.

Tightening torque:

73–106 N·m {7.4–10.9 kgf·cm, 54–78.8 ft·lbf}

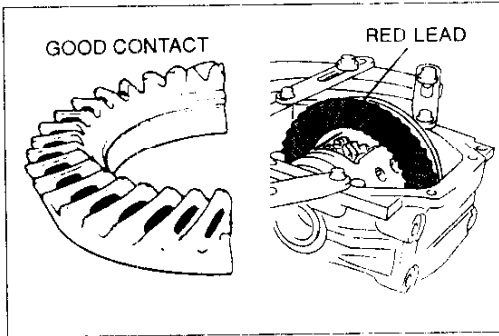

29L0MX 125

Inspection and adjustment of tooth contact

1. Coat both surfaces of 6–8 teeth of the ring gear with a uniformly thin coat of red lead.
2. While moving the ring gear back and forth by hand, rotate the drive pinion several times and check the tooth contact.
3. If the tooth contact is good, wipe off the red lead.

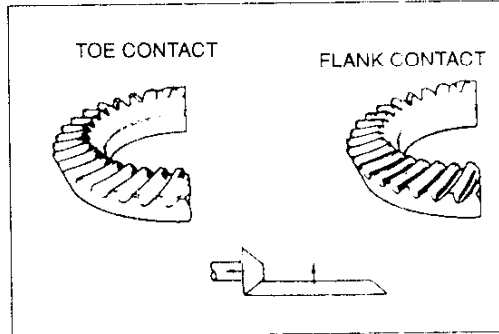

29110MX 126

4. If it is not good, readjust the pinion height, and then adjust the backlash.

(1) Toe and flank contact

Replace the spacer with a thinner one to move the drive pinion outward.

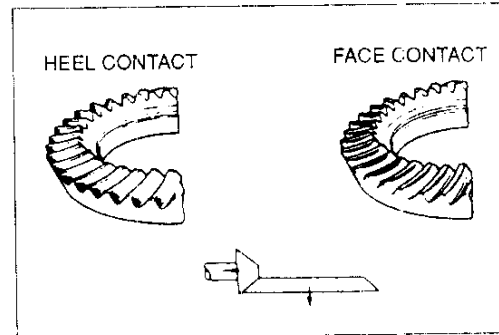

29U0MX 127

(2) Heel and face contact

Replace the spacer with a thicker one to bring the drive pinion inward.